

CIP Training

Plockmatic
SquareBack
Trimmer

Operators Guide

RICOH
imagine. change.

PLOCKMATIC

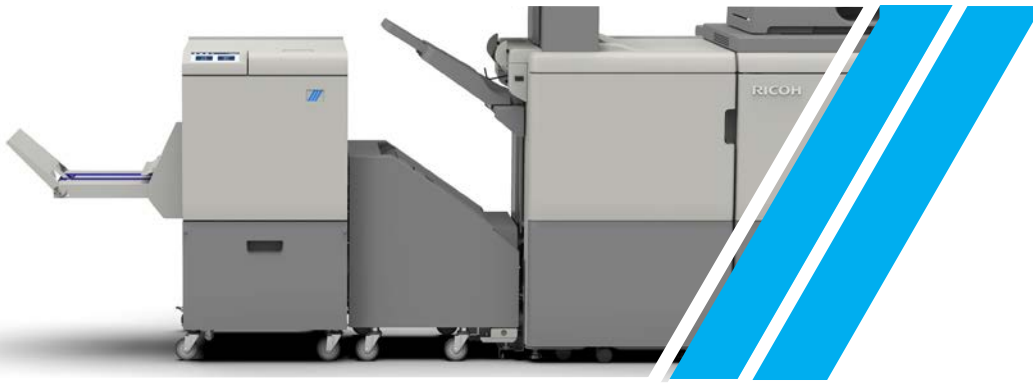

Plockmatic SBT **for Ricoh**
SquareBack Trimmer

Introduction

This manual contains instructions on the operation and maintenance of this machine. To get maximum versatility from this machine all operators should carefully read and follow the instructions in this manual. Keep this manual in a handy place near the machine.

Please read the Safety Information before using this machine. It contains information related to USER SAFETY and PREVENTING EQUIPMENT PROBLEMS.

How to read this manual

Notation conventions

Whenever necessary, the following points for attention are indicated in this manual.

WARNING:

Indicates a potentially hazardous situation which, if instructions are not followed, could result in death or serious injury.

CAUTION:

Indicates a potentiality hazardous situation which, if instructions are not followed, may result in minor or moderate injury or damage to machine or property.

NOTE:

This sign refers to:

- *Remarks for making the operation much easier. You get practical hints or knowledge to assist you in the machine operation such as:*
- *Preparations required before operating*
 - *How to prevent papers from being misfed or damaged*
 - *Precautions required or actions to take after misoperation*
- *Limitations like numerical limits, functions that cannot be used together or conditions, under which a particular function cannot be used or obtained.*
- *Information.*

CIP Training Plockmatic SquareBack Trimmer

Safety Information

When using this machine, following safety precautions should always be followed.

Safety during operation

WARNING:

- To avoid hazardous situations like for instance electric shock or danger while exposed to moving, rotating or cutting devices, do not remove any covers, guards or screws other than those specified in this manual.
- Turn off the power and disconnect the power plug (by pulling the plug, not the cable) if any of the following conditions exists:
 - You drop objects or spill something into the equipment.
 - You suspect that your equipment needs service or repair.
 - Your equipment's covers has been damaged.
 - You notice unusual noises or odours when operating the equipment.
 - If the power cable or plug becomes worn out or otherwise damaged.
 - Before cleaning and care (unless otherwise specifically instructed).
- Electromagnetic compliance:
 - This is a Class A product. In a domestic environment this product may cause radio interference in which case the user may be required to take adequate measures.
 - The product (System) which is connected to this machine will be class A.

General safety

WARNING:

- Always connect the equipment to a properly grounded power source (wall outlet). If in doubt, have the power source checked by a qualified electrician.
- Improper grounding of the equipment can result in electrical shock. Never connect the machine to a power source that lacks a ground connection terminal. This machine is destined for specific purpose only. Any use going beyond this specific purpose is re-garded as beyond the determination. The manufacturer will not be liable for damages resulting from any use beyond the determination, not allowed operation, respectively. The user alone bears the risk.
- Do not make arbitrary changes or modifications to the machine. The manufacturer will not be liable for modifications made at the machine on your own and damages result-ing thereof. EC declaration of conformity and the mark CE will be invalidated, if you make changes at the machine or at the individual components.
- Do not override or bypass electrical or mechanical interlock devices.
- The machine is to be used only by authorized and instructed persons. The responsibilities on operating the machine have to be strictly laid down and observed so that there are no unclear competencies regarding safety aspects.
- Vent holes serve for air circulation to protect the machine from overheating. Make sure that the holes are not covered.
- Do not expose fingers or other parts of the body to moving, rotating or cutting devices such as for instance between upper and lower trimmer knives.
- Always locate the equipment on a solid support surface with adequate strength tor the weight of the machine. This equipment is not suitable for use in locations where children are likely to be present.
- This equipment is only intended for instructed and qualified operators.
- Operators shall be familiar with the safety information in this manual and other safety information supplied with this equipment.

CIP Training Plockmatic SquareBack Trimmer

Safety Information

CAUTION:

- The machine and its peripherals must be installed and maintained by a customer service representative who has completed the training course on those models.
- Always follow all warnings marked on, or supplied with, the equipment.
- When you disconnect the power plug from the wall outlet, always pull the plug (not the cable).
- Disconnect the power cord before you move the machine. While moving the machine, always exercise care and make sure that the power cord will not be damaged under the machine.
- Always contact service if relocating the equipment.
- Do not move the machine while the machine is running.
- Do not open covers while the machine is running.
- Do not switch off the power while the machine is running. Make sure the machine cycle has ended.
- Lay the power cord in a way that nobody will stumble over it. Do not place things on the cord.
- Never attempt any maintenance function that is not specifically described in this documentation.
- Always keep magnets and all devices with strong magnetic fields away from the machine.
- If the place of installation is air-conditioned or heated, do not place the machine where it will be:
 - Subject to sudden temperature changes.
 - Directly exposed to cool air from an air-conditioner.
 - Directly exposed to heat from a heater.
- If the machine is not used over an extended period of time it should be unplugged to prevent damage in the case of overload.

NOTE:

- ***The indications like front and rear, left and right refer to the paper transport direction.***
- ***The operator manual always has to be available at the place of use of the machine.***
- ***In the interest of technical development the company reserves the right to make alterations to specifications without prior notice!***

WARNING:

Do not put fingers or other parts between moving parts.

CIP Training Plockmatic SquareBack Trimmer

What You Can Do With This Machine

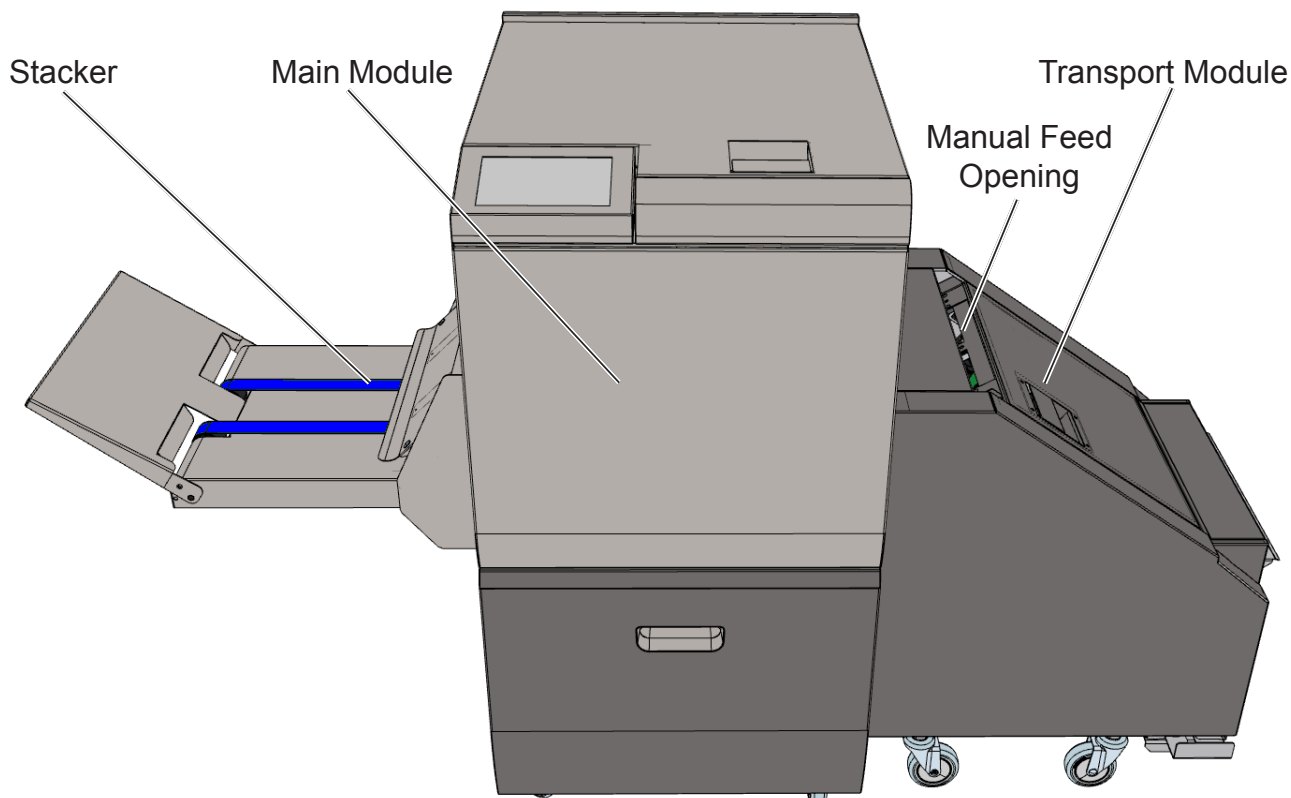

The Plockmatic SquareBack Trimmer is a machine that allows for Squarefolding and Trimming of booklets.

Stapled booklets are fed in the machine from the upstream device through the Transport Module and are delivered on the Stacker.

The user has also the possibility to Manual Feed booklets into the machine through the manual hand-feed opening, thus using the Main Module as a stand-alone machine.

When the booklets are fed into the Main Module, an align module transports them into the trimming area, where trims on the sides of the booklets are performed.

Finally, the booklets get squarefolded and fed out on the belt stacker.

CIP Training Plockmatic SquareBack Trimmer

Guide To Components

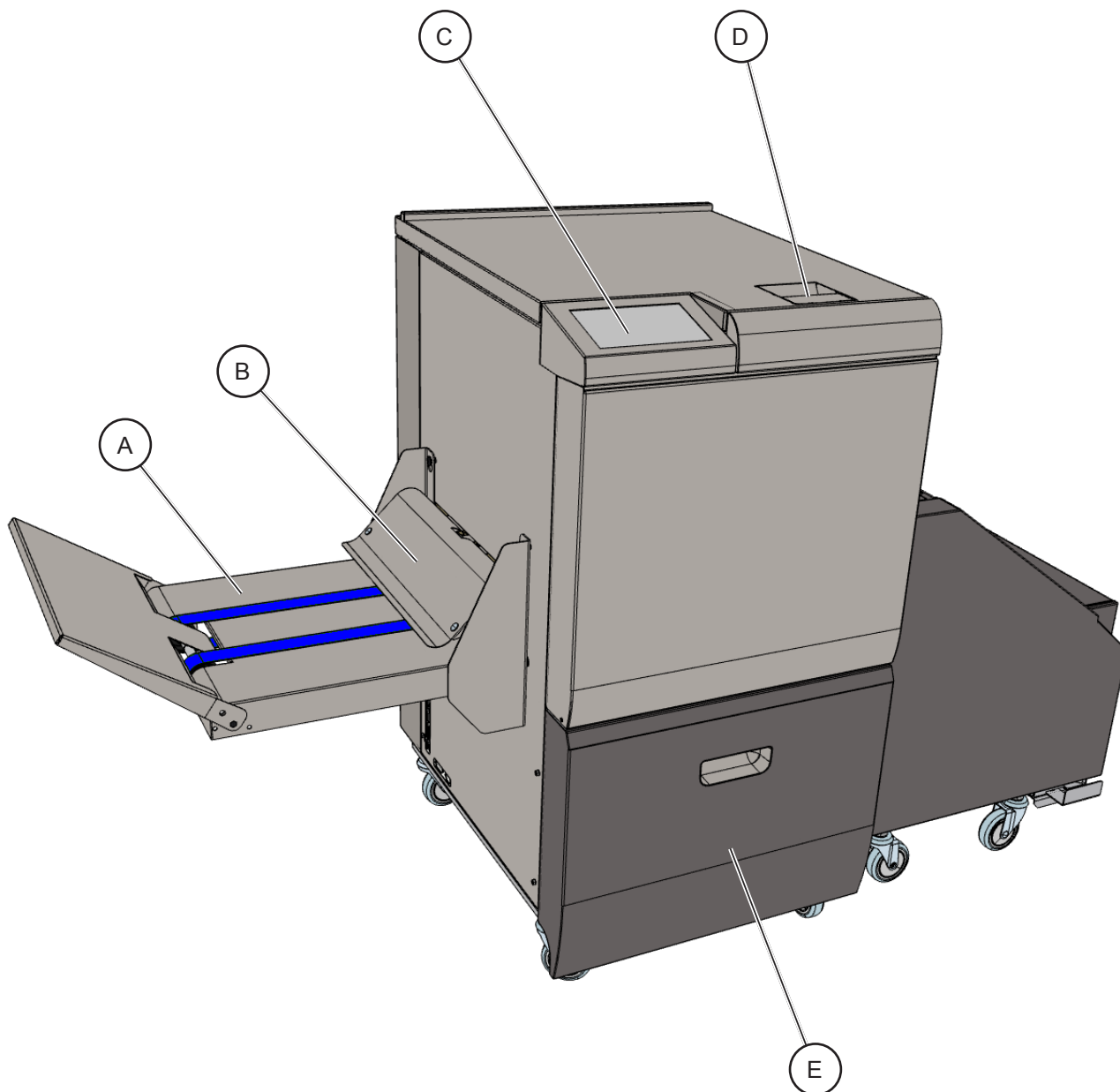

- A. Belt Stacker
- B. Belt Stacker Cover
- C. Graphical User Interface (GUI)

- D. Latch Handle
- E. Waste Tray

CIP Training Plockmatic SquareBack Trimmer

Guide To Components

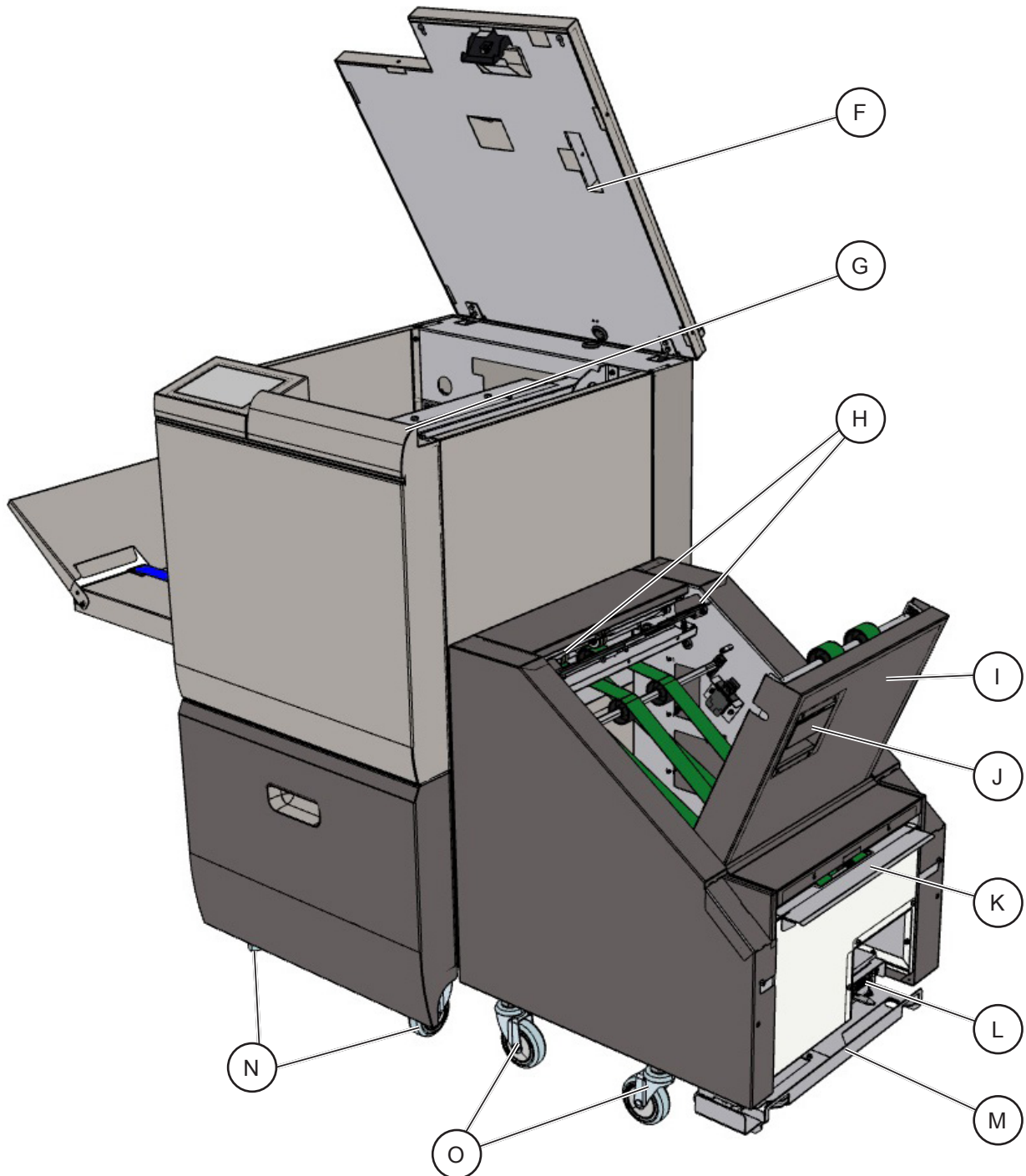

- F. Top Cover Main Module
- G. Power Switch
- H. Paper Guides for manual feed
- I. Top Cover Transport Module
- J. Latch Handle

- K. Paper Guides
- L. Connector
- M. Docking Assembly
- N. Casters with lock
- O. Casters without lock

CIP Training Plockmatic SquareBack Trimmer

Guide To Components

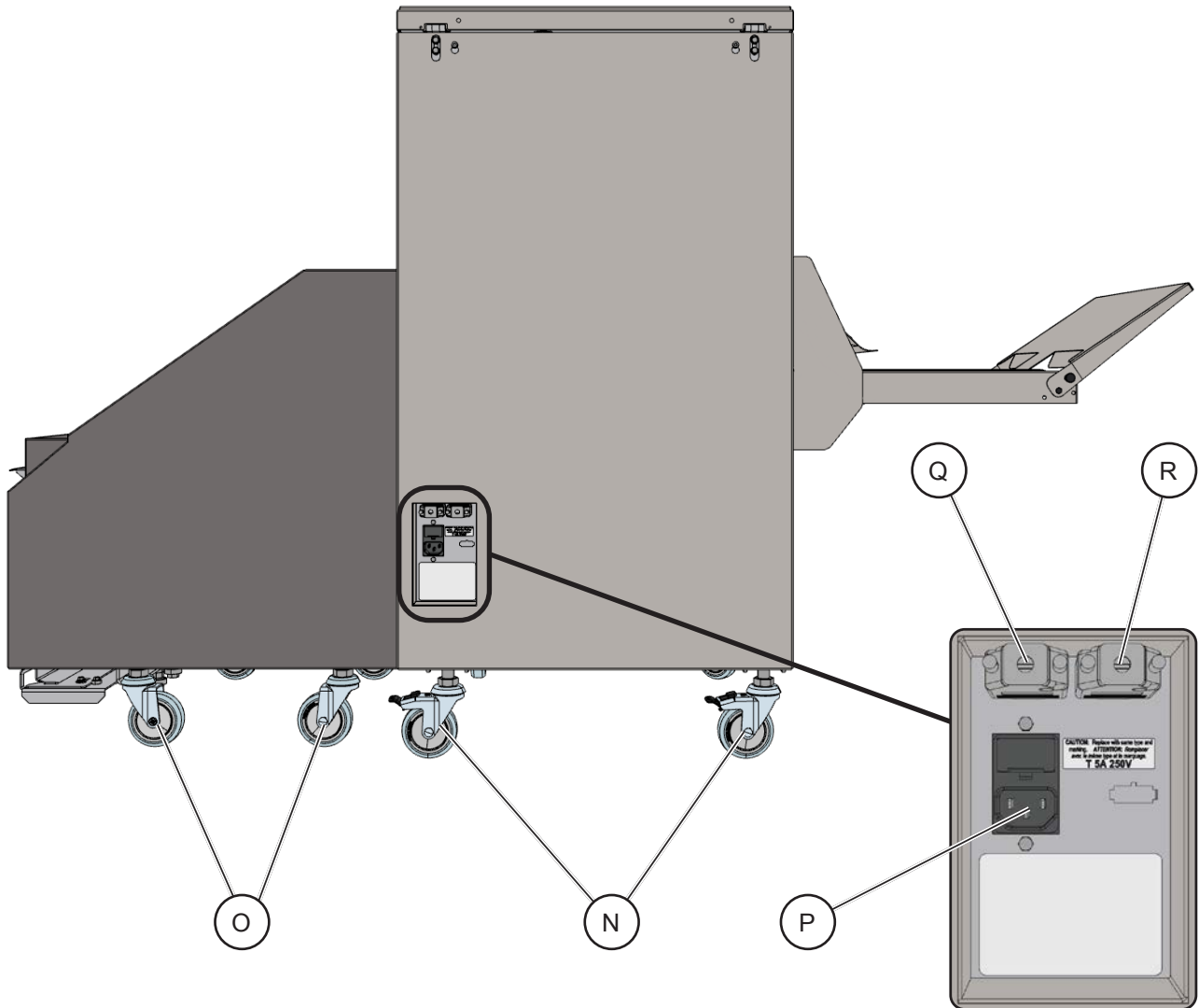

- P. Power Socket
- Q. Shorting Plug
- R. Shorting Plug

CIP Training Plockmatic SquareBack Trimmer

Graphical User Interface

The Plockmatic SquareBack Trimmer has a Graphical User Interface (GUI) / Control Panel which allows for viewing or adjusting local machine settings and properties.

Control Panel

The control panel is of touch screen type. Point at the screen and press the “button” to reach the desired function or change the desired setting.



Welcome screen

When the system power is switched on, a welcome screen will be displayed on the screen while the machine initializes.

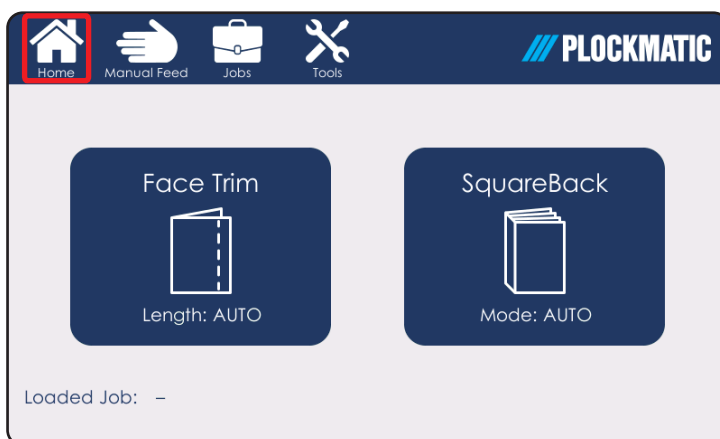

Main Menu

Once the system is ready, the Main Menu will be shown.

From the Main Menu one can access the Face Trim and Square Back options.

The Manual Feed, Jobs and Tools sub-menus are reached from the top ribbon interface.

Selecting 'Home' from any sub-menu will bring the user back to the Main Menu.

CIP Training Plockmatic SquareBack Trimmer

Graphical User Interface

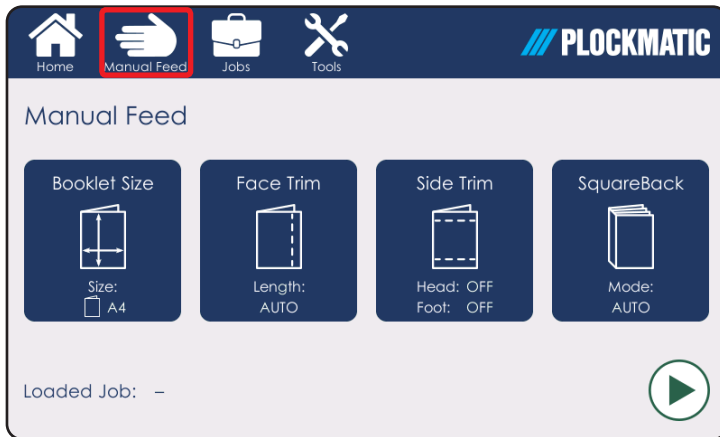

Manual Feed Menu

Pressing [Manual Feed] on the GUI will open the Manual Feed sub-menu.

The user has to choose and adjust settings for the Manual Feed mode in this sub-menu (see section 3 of this manual for a complete description of the Manual Feed Mode and Menu).



Jobs

Pressing [Jobs] on the top ribbon of the screen will open the Jobs sub-menu.

This sub-menu allows for programming of jobs. See section 4 of this manual for a complete description of the Jobs Menu.

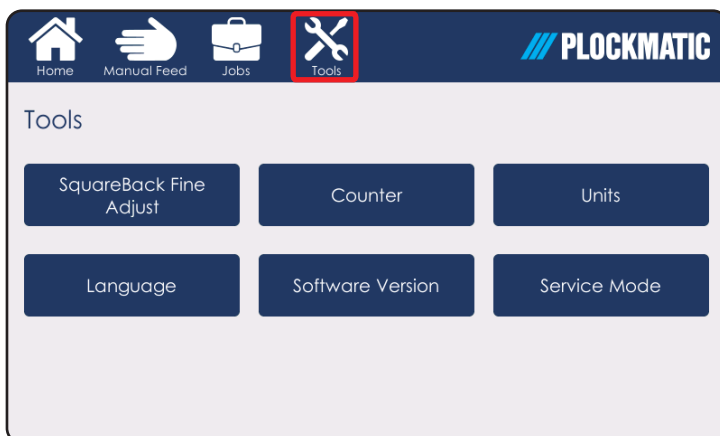

Tools

The Tools sub-menu contains a number of options that will allow the user to:

- Fine adjust settings for the Square Back option,
- View and reset the counter,
- Choose the Units,
- Select the language,
- View the Software Version installed on the machine.

The Service Mode is to be used only by authorized technicians (see section 5 of this manual for a complete description of the Tools Menu).

Basics

Turning On / Off the Main Power

Power switch

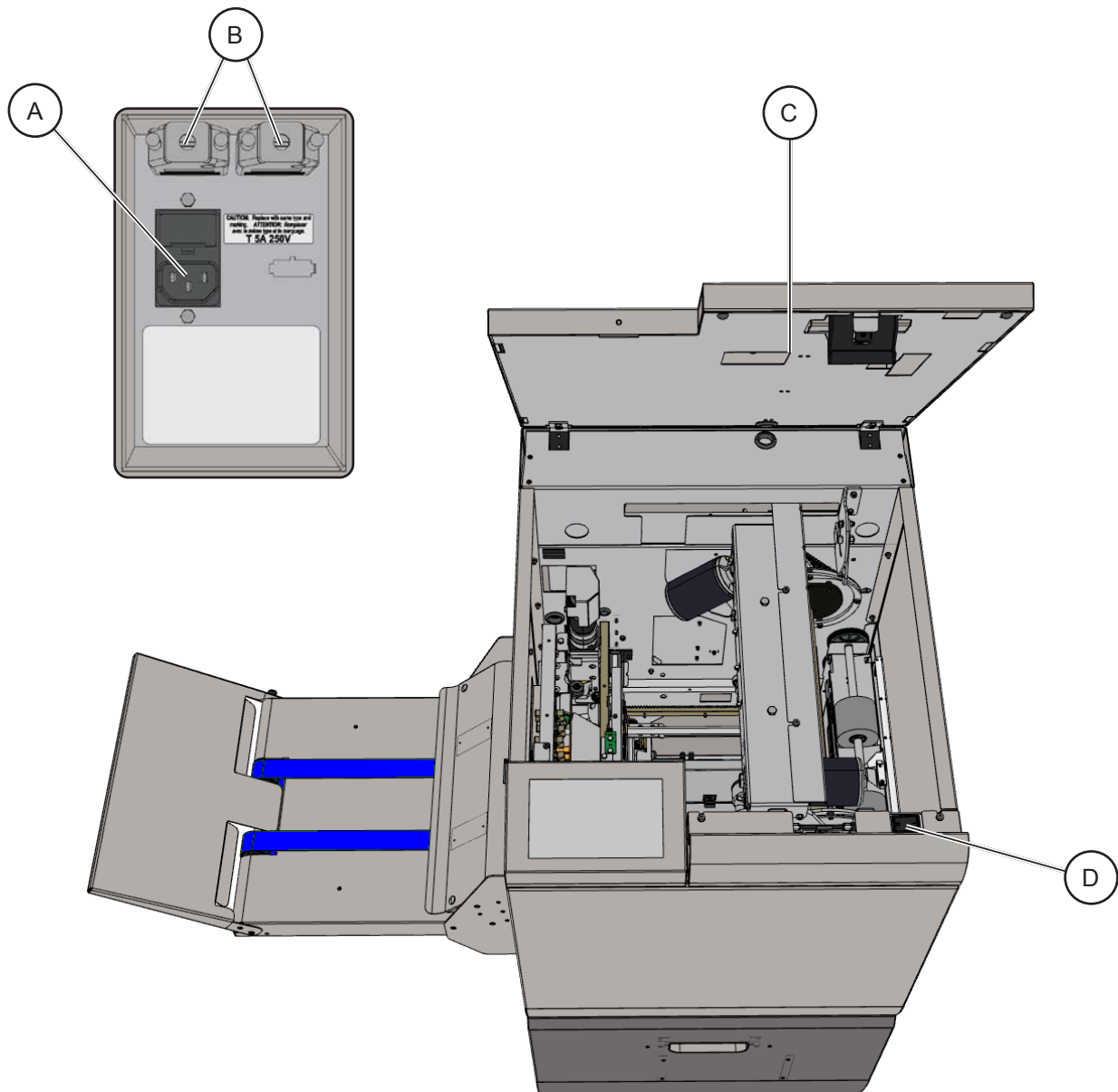

- 1 Ensure that the main power cord is plugged into the wall and to the back of the Main Module [A].
- 2 Make sure the two shorting plugs are plugged in, as shown in the picture [B].
- 3 Open the top lid [C].
- 4 Toggle on/off the Power Switch [D].
- 5 Close the top lid.

Basics

Emptying the waste bin

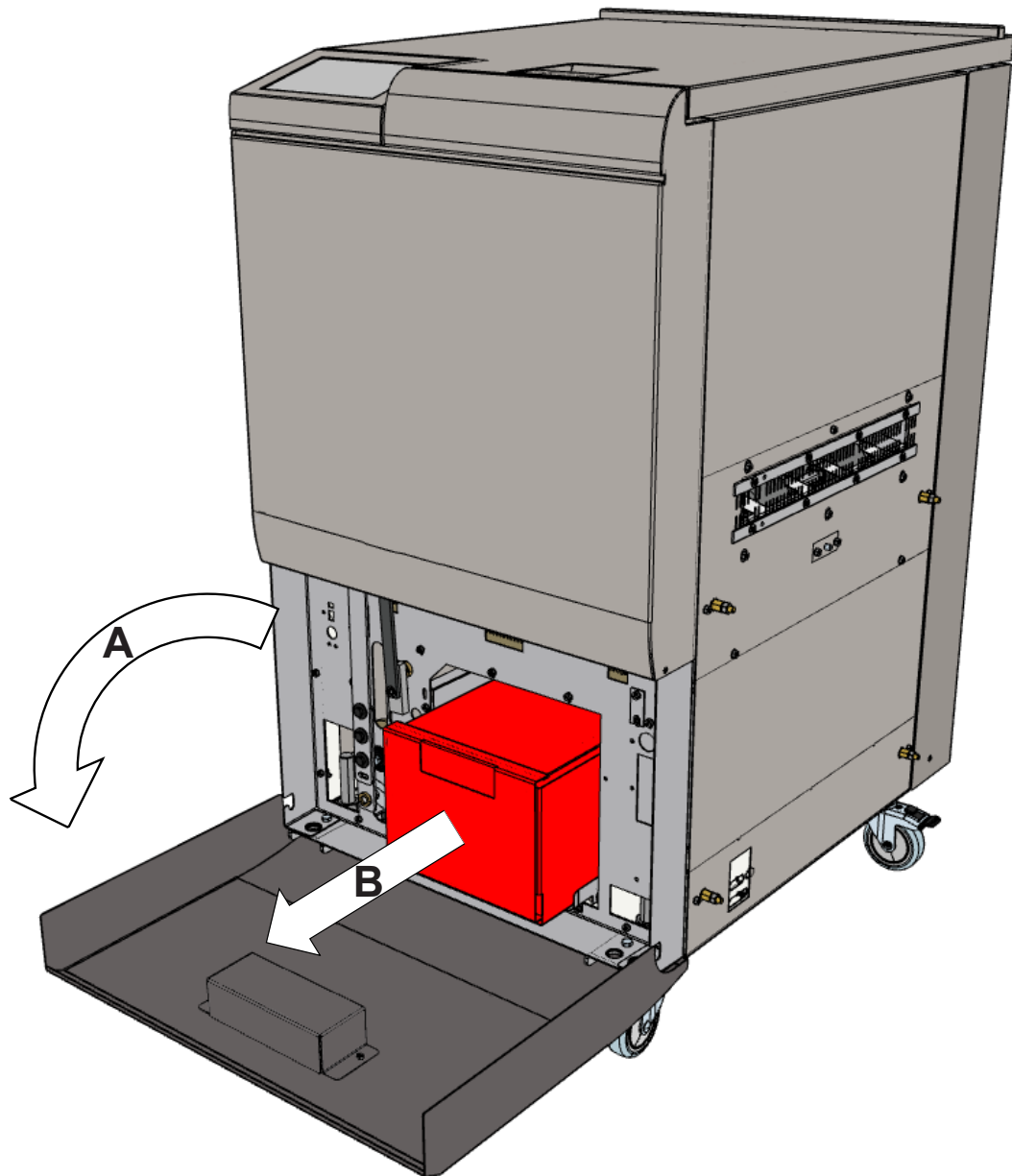

- 1.** Pull up and then out the lower front cover to open it [A].
- 2.** Remove [B] the waste bin (in red) and empty it.
- 3.** Replace the waste bin and close the waste bin cover.

Basics

Docking / Undocking

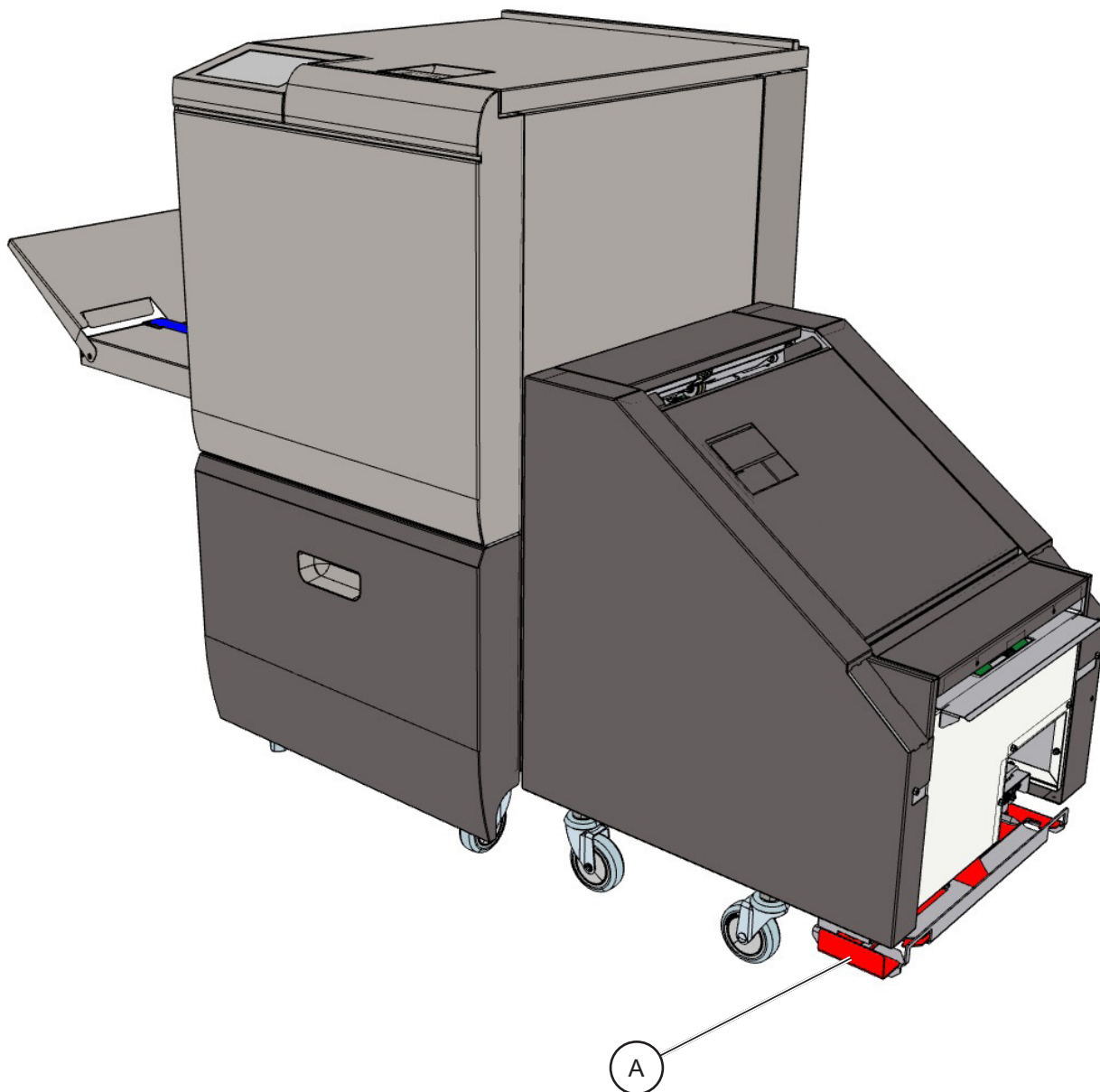

- 1 Push the docking plate [A] to undock the SquareBack Trimmer.
- 2 Push the SquareBack Trimmer away from the printer.



NOTE:

Reverse procedure to dock the SquareBack Trimmer.

Setting Up a Job

In-line mode

Setting up the Fiery controller

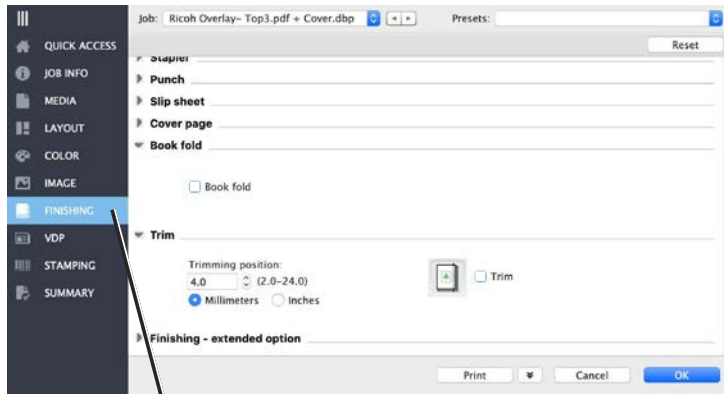

A

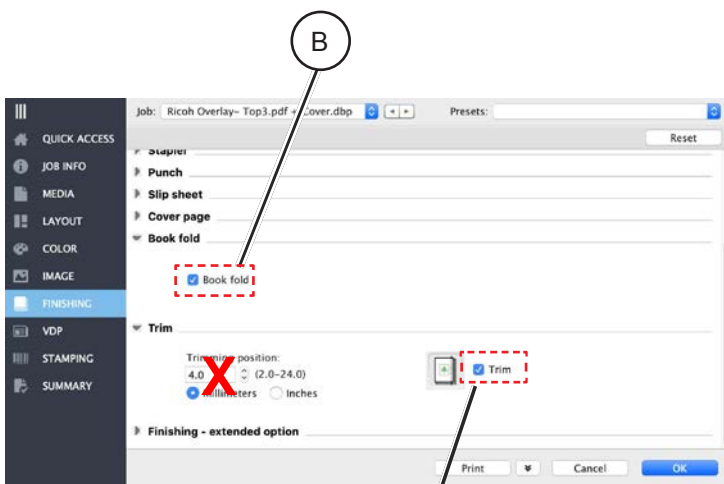

B

C

Setting up the Fiery

This procedure describes how to set up the Fiery when running the SquareBack Trimmer. The SBT receives information about the finishing of the booklets from the Fiery job properties.

1. Within the Job Properties select the Finishing Options [A]
2. To activate the SquareBack function on the Plockmatic SBT select the 'Book Fold' option [B].
3. To activate the Trimming function select 'Trim' [C].
4. Disregard the 'Trimming Position' This setting does not apply to the SBT.

 NOTE:

The amount of the SquareBack and the amount of trim is set on the SBT LCD panel.

CIP Training Plockmatic SquareBack Trimmer

Setting Up a Job

Main Menu

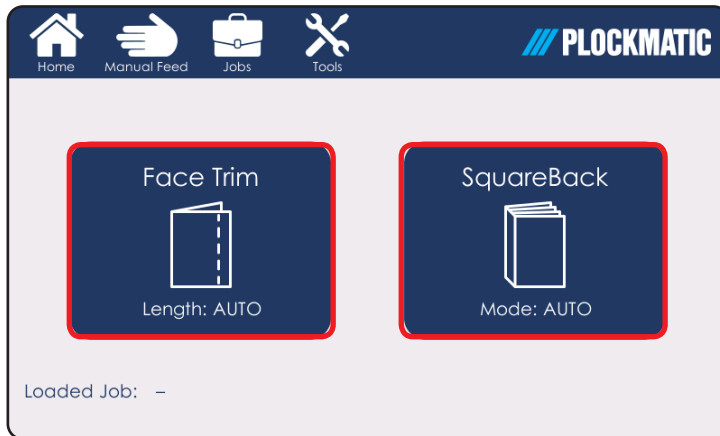

Main Menu

This screen allows the operator to open the "Face Trim" and "Square Back" sub-menus.

Face Trim

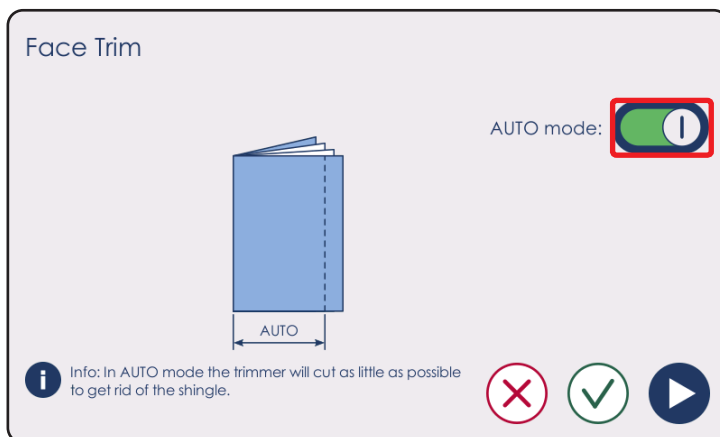

Face Trim

This function trims the front edge of the booklet to get an even length on every page.

When Auto mode is on, a minimum trim is performed on the booklet. If the amount of trim is not satisfactory, the user can adjust it manually by tapping on the green switch, which will turn the Auto mode off.

 **NOTE:**

The printer's settings override the SquareBack Trimmer settings, therefore, if this function is turned off on the printer, it will be turned off automatically on the SBT.

When turned on on the printer, the SBT will apply auto settings again.

CIP Training Plockmatic SquareBack Trimmer

Setting Up a Job

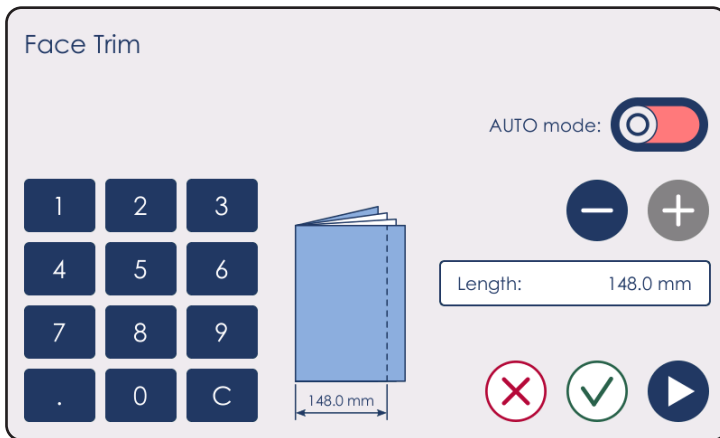

To adjust the amount of face trim, press [+] or [-] or enter the desired length of the booklet using the numeric keypad.

NOTE:

If the values chosen are out of the paper bounds, the lengths will automatically be adjusted to the limit values.

Push the green check mark to confirm the changes or the red cross to discard them and to go back to the main menu. Pushing the blue play button will bring the user to the next setting: "Square Back".

Square Back

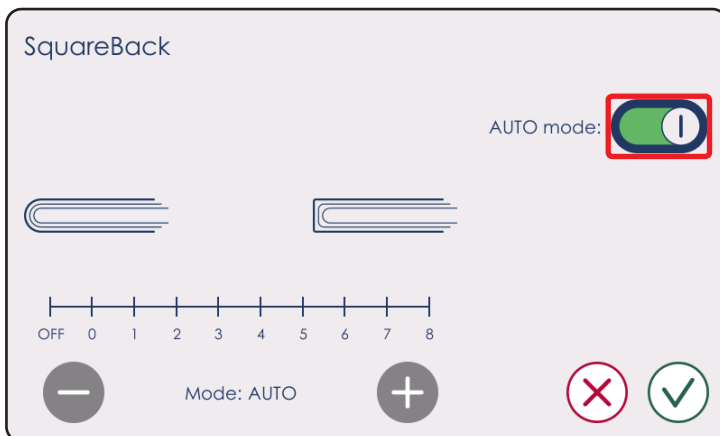

Square Back

The operator has the option of sharpening or softening the square edges of the finished booklet based on application or preference. The Auto mode is on by default but, if the Square Back is not satisfactory, the user can adjust it manually by tapping on the green switch, which will turn the Auto mode off.

NOTE:

The printer's settings override the SquareBack Trimmer settings, therefore, if this function is turned off on the printer, it will be turned off automatically on the SBT. When turned on on the printer, the SBT will apply auto settings again.

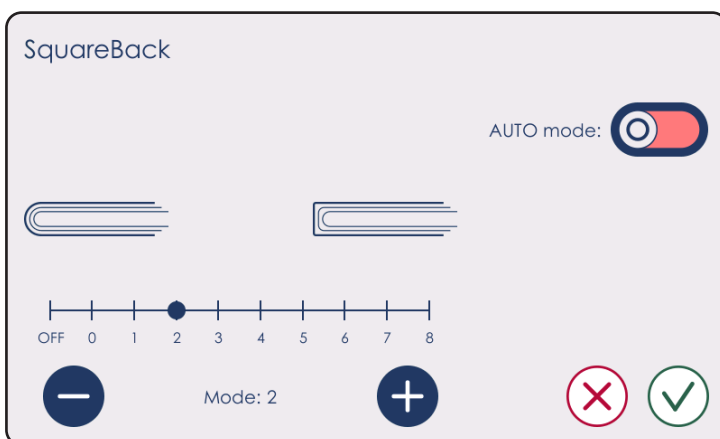

NOTE:

If the Square Back does not give satisfactory results, it might need to be Fine Adjusted. To do so, see "Square Back Fine Adjustment" under section 5 of this manual.

To adjust the amount of Square Back pressure, press [+] for sharper edges and [-] for softer edges.

Push the green check mark to confirm the changes or the red cross to discard them and to go back to the main menu.

Setting Up a Job

Booklet Production

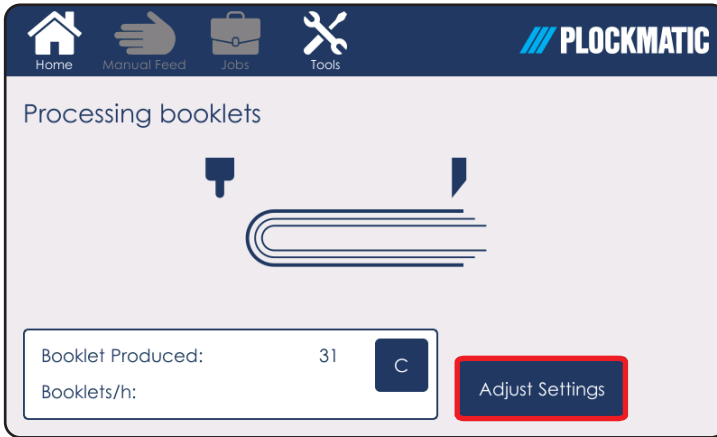

Booklet Production

When the printer is started, Booklet Production starts automatically and this screen is shown on the GUI.

The operator can adjust the finishing settings while the booklets are being produced by pressing [Adjust Settings].

This will show again the Main Menu on the screen.

The user can then modify the finishing settings as described earlier in this section.

 **NOTE:**

while producing the book-lets, due to physical constraints, Face Trim can only be adjusted by a maximum of +3mm or - 3mm.

CIP Training Plockmatic SquareBack Trimmer

Manual Feed Mode

The SquareBack Trimmer can be operated in two modes: in-line Mode, when used together with a printer or Manual Feed Mode, either working as a stand-alone unit or connected to a printer but hand fed with booklets produced by another printer.

 **NOTE:** it is not possible to use both the In-line and the manual feed features at the same time: trying to feed booklets manually when the machine is being used In-line with a printer will cause a jam.

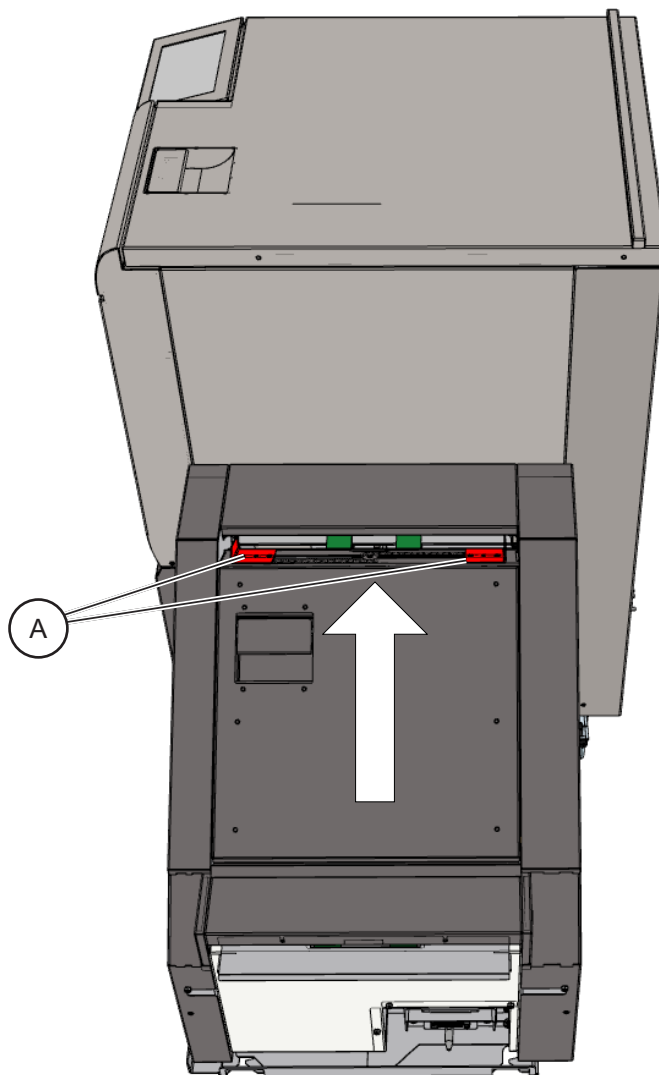

The paper guides [A] are used in Manual Feed Mode and are meant to be adjusted depending on the size of the booklet that will be fed into the machine. Refer to "**Feeding Booklets**" in this section to understand how to correctly feed a booklet in the machine.

CIP Training Plockmatic SquareBack Trimmer

Manual Feed Mode

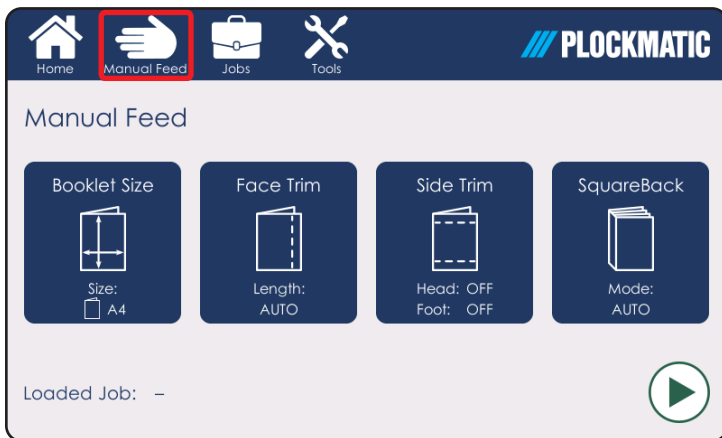

Manual Feed Menu

Select the Manual Feed option by tapping on the highlighted button on the top ribbon.

Here the operator has to choose the size of the booklet fed and the type of finishing desired on the booklet before starting the production process.

Booklet Size

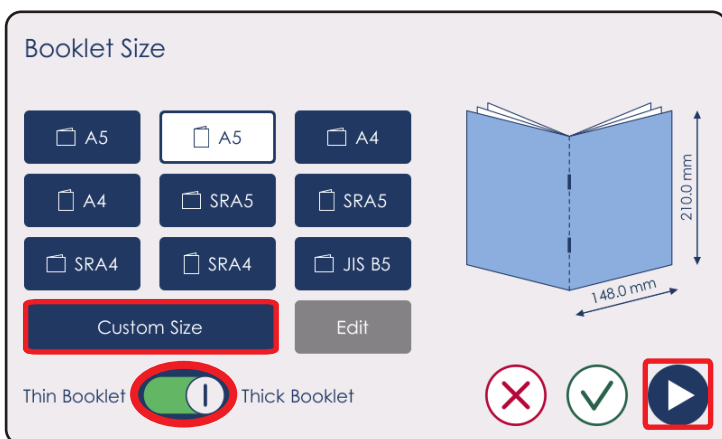

Booklet Size

This menu allows the user to choose the finished booklet size: the user can either select one of the standard sizes or input a custom size.

Toggle the Thin / Thick Booklet option depending on the size: choose "Thick Booklet" when the booklet is thicker than 1.3 mm or 0.051 inches (approximately 6 sheets 80 g/m²), choose "Thin Booklet" when the booklet is thinner than 1.3 mm.

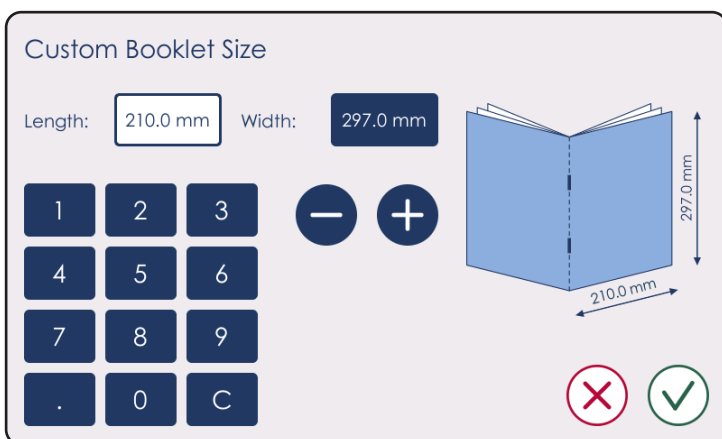

NOTE:

Selecting [Custom Size] only, will recall the last custom size inputted. Selecting [Custom Size] and then [Edit] will open a new screen that allows for inputting of custom values. If the values chosen are out of the paper bounds, the lengths will automatically be adjusted to the limit values.

Push the green check mark to confirm the changes or the red cross to discard them and to go back to the main menu. Pushing the blue play button will bring the user to the next setting: "Face Trim".

CIP Training Plockmatic SquareBack Trimmer

Face Trim

Face Trim

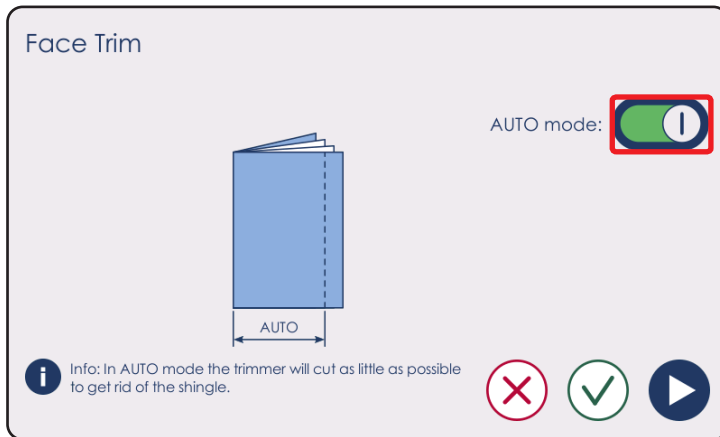

Face Trim

This function trims the front edge of the booklet to get an even length on every page.

When Auto mode is on, a minimum trim is performed on the booklet. If the amount of trim is not satisfactory, the user can adjust it manually by tapping on the green switch, which will turn the Auto mode off.

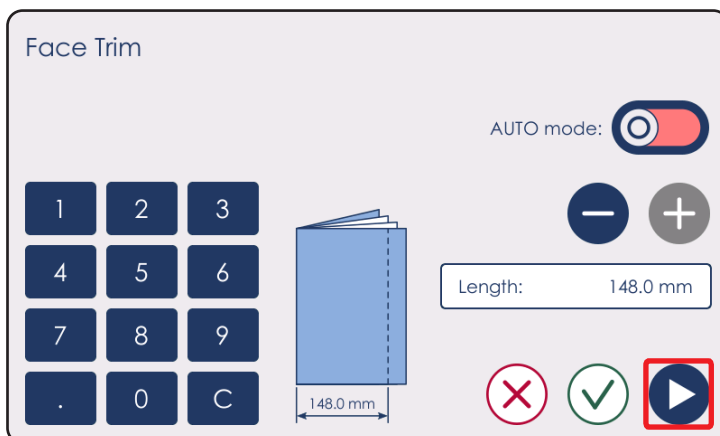

To adjust the amount of face trim, press [+] or [-] or enter the desired length of the booklet using the numeric keypad.

NOTE:

If the values chosen are out of the paper bounds, the lengths will automatically be adjusted to the limit values.

Push the green check mark to confirm the changes or the red cross to discard them and to go back to the main menu. Pushing the blue play button will bring the user to the next setting: "Side Trim".

Side Trim

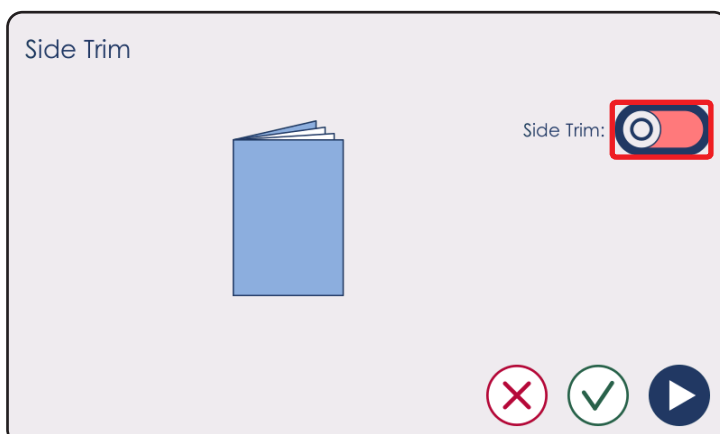

Side Trim

This function trims the sides of the booklet.

Side trim is set off by default and can be turned on by toggling the switch.

NOTE:

Use side trim with caution. Please note the position of the staples, set head and foot trims so that the staples are not cut.

CIP Training Plockmatic SquareBack Trimmer

Side Trim

Side Trim

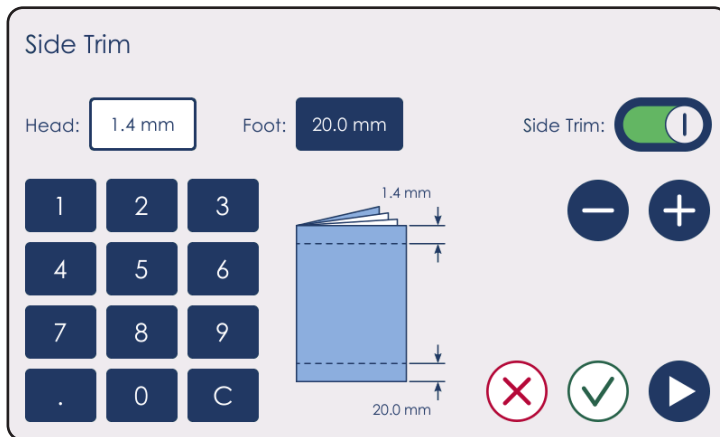

To adjust the amount of side trim, press [+] or [-] or enter the desired length of the booklet using the numeric keypad.

NOTE:
The maximum amount of trimming on each side is 24 mm / 0.94".

Push the green check mark to confirm the changes or the red cross to discard them and to go back to the main menu. Pushing the blue play button will bring the user to the next setting: "Square Back".

Square Back

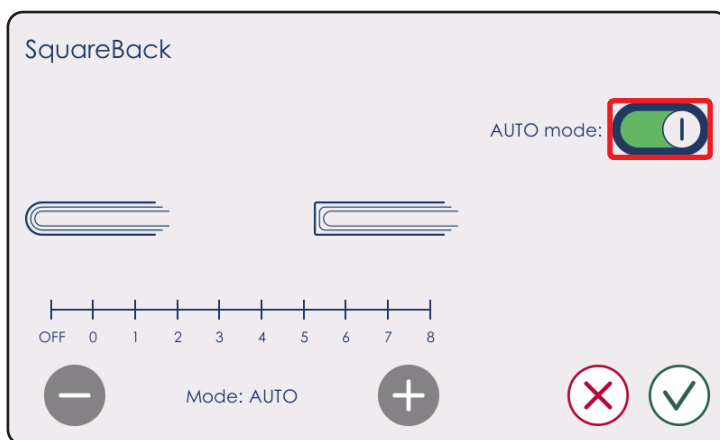

Square Back

The operator has the option of sharpening or softening the square edges of the finished booklet based on application or preference.

The Auto mode is on by default but, if the Square Back is not satisfactory, the user can adjust it manually by tapping on the green switch, which will turn the Auto mode off.

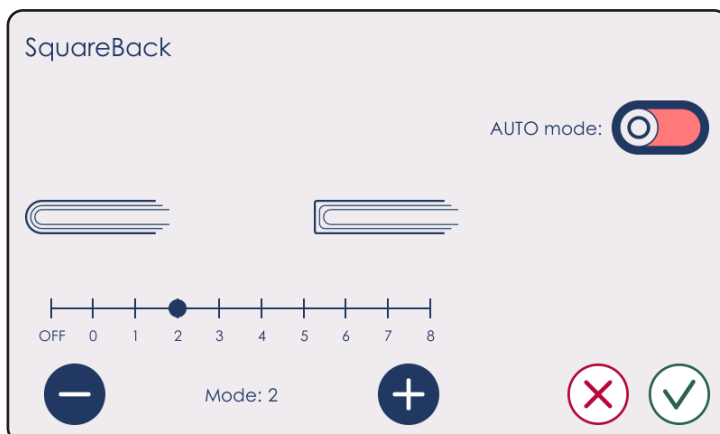

To adjust the amount of Square Back pressure, press [+] for sharper edges and [-] for softer edges.

Push the green check mark to confirm the changes or the red cross to discard them and to go back to the main menu.

NOTE:
If the Square Back does not give satisfactory results, it might need to be Fine Adjusted. To do so, see "Square Back Fine Adjustment" under section 5 of this manual.

Booklet Production

Booklet Production

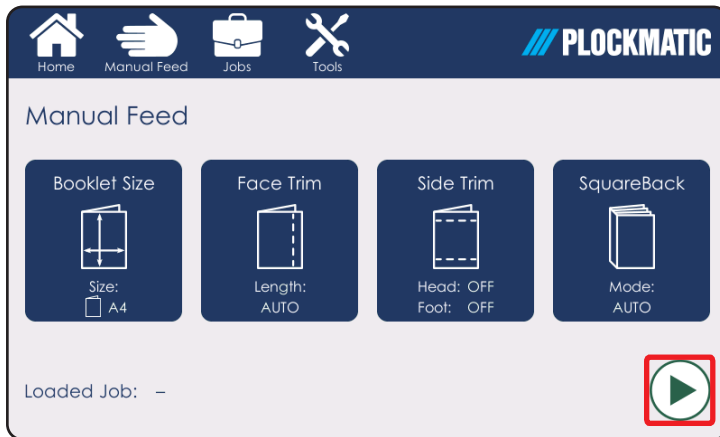

Booklet Production

Once all the settings have been adjusted, press on the play button to start Booklet Production.

Refer to "**Feeding Booklets**" in this section to understand how to correctly feed a booklet in the machine.

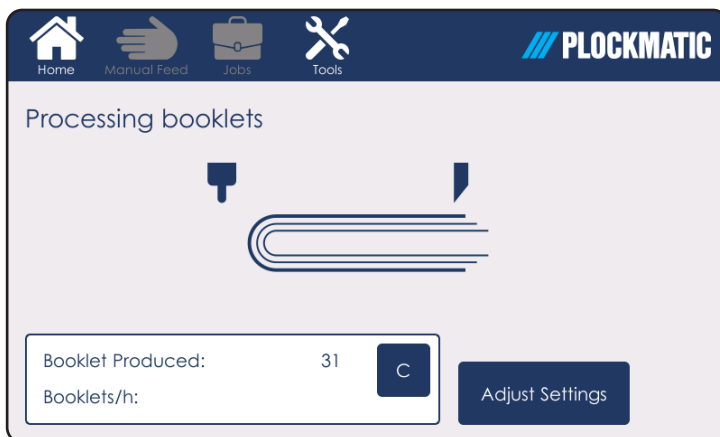

When the Booklet Production is started, this screen is shown.

The operator can adjust some settings while the booklets are being produced by pressing [Adjust Settings]. This will bring the user back to the Manual Feed Menu.

The user can then modify the finishing settings as described earlier in this section.

NOTE:

Square Folding can be changed without any limitation when running the machine, while Trimming can be adjusted only in the range of ± 3 mm / ± 0.12 ".

If trimming needs to be adjusted further, operations first need to be stopped: this is done by pressing the red stop button.

Feeding Booklets

Feeding Booklets

Booklets are fed in the machine through the Manual Hand Feed Opening. Set the side guides on the hand feed opening to the correct booklet size before starting the feeding procedure to make sure that the booklets enter centred into the machine.

If performing side trimming as well, the booklets will need to be fed three times each to allow the machine for trimming of the sides of the booklets as well. When side trimming is enabled, the "manual feed guide" will appear on the screen to guide the user through the procedure. Follow the three steps as shown on the screen and as described in this section.

Feeding Booklets

Feeding Booklets

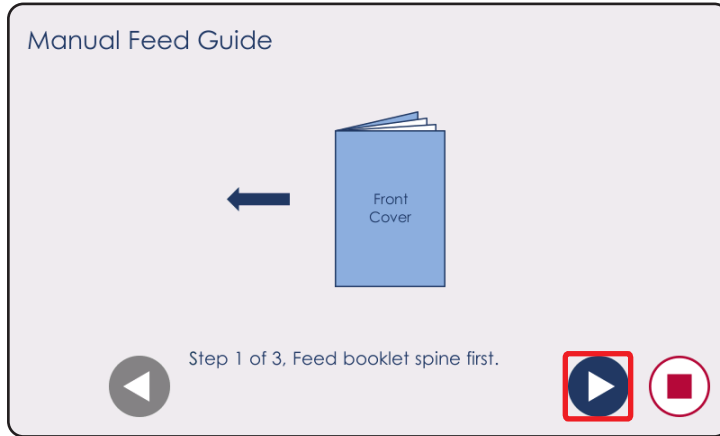

First step

Feed the booklet(s) in the machine with the booklet spine facing the infeed side of the machine.

If trimming more than one booklet, the user can feed as many booklets as needed before proceeding to the next step.

Pushing the blue play button will bring the user to the next page of the guided procedure.

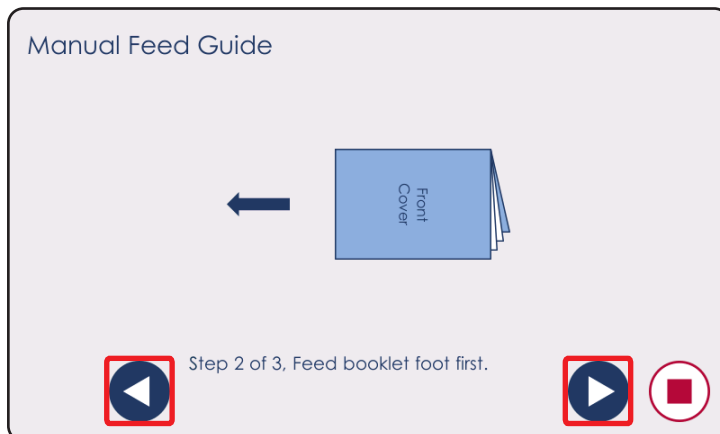

Second step

Feed the booklet(s) in the machine with the booklet foot facing the infeed side of the machine.

Pushing the right play button will bring the user to the next page of the guided procedure, pushing the left play button will bring the user to the previous page of the guided procedure.

 *NOTE: the booklet spine should be oriented towards the non-operator side of the machine, as shown on the User Interface.*

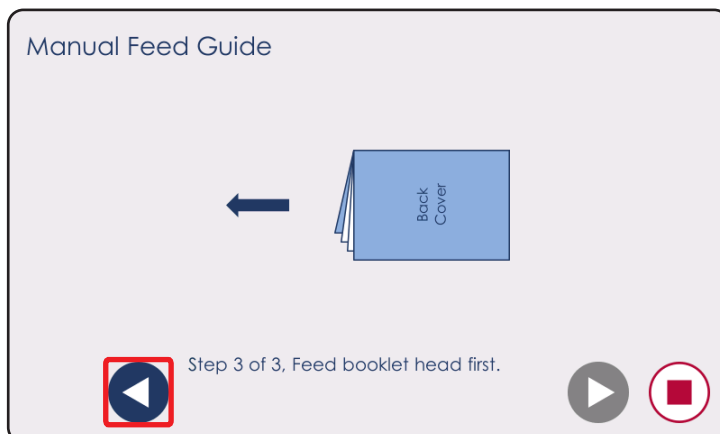

Third step

Feed the booklet(s) in the machine with the booklet head facing the infeed side of the machine.

Pushing the blue play button will bring the user to the previous page of the guided procedure.

 *NOTE: the booklet spine should be oriented towards the non-operator side of the machine, as shown on the User Interface.*

CIP Training Plockmatic SquareBack Trimmer

Jobs

Handling Jobs

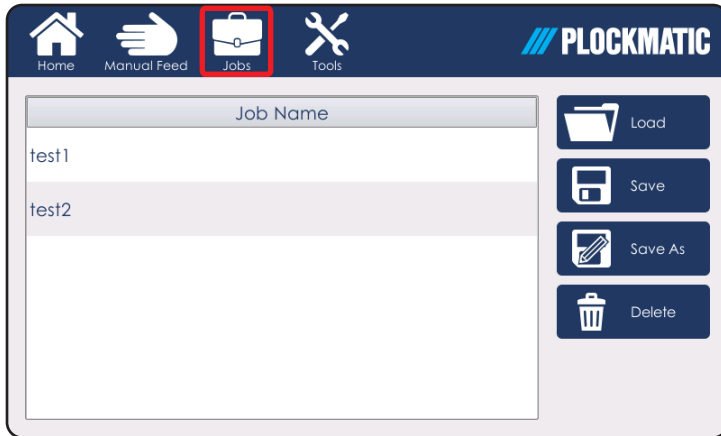

Pressing [Jobs] on the top ribbon, opens the Jobs sub-menu.

From here the operator can open a saved job. Saved jobs can be customized and deleted.

Loading a Job

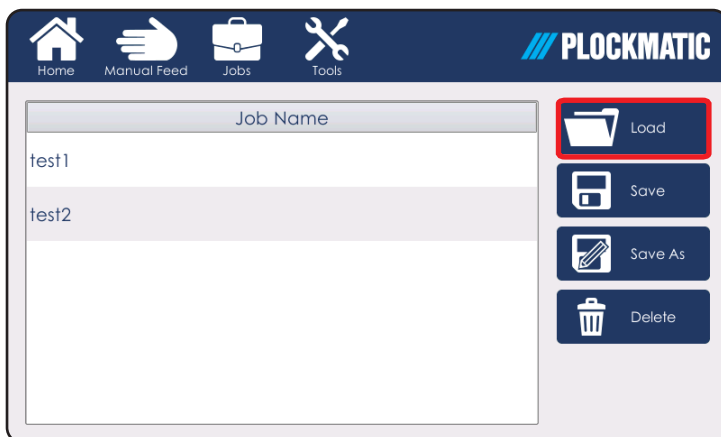

The user can load a job by selecting it from the saved jobs list and then pushing [Load].

Saving a Job

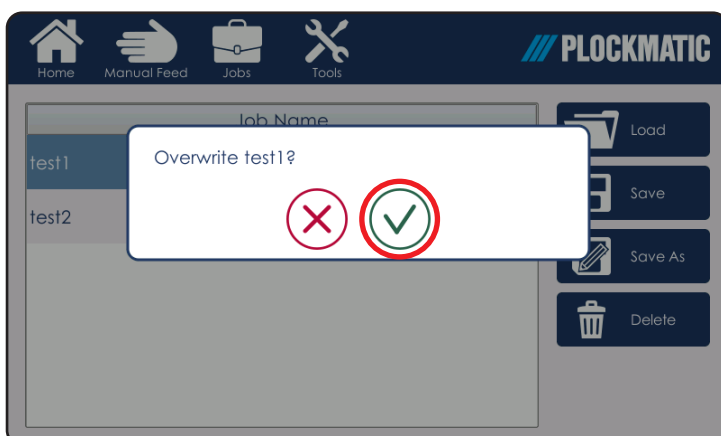

After having selected the desired Job from the job list, push [Save] to save changes to it.

Push the green check mark to confirm.

CIP Training Plockmatic SquareBack Trimmer

Jobs

Saving a New Job

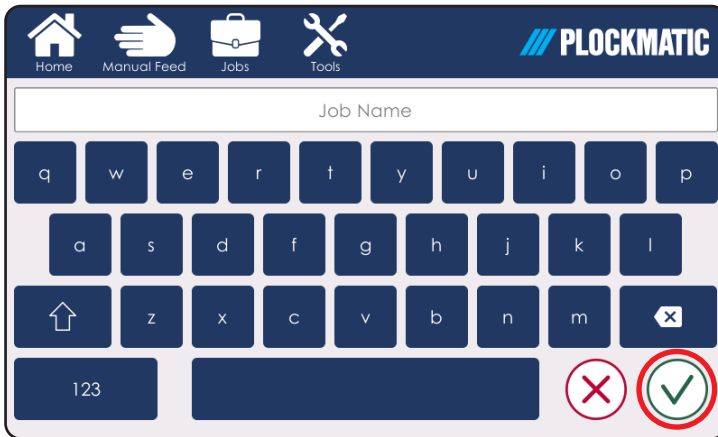

Push [Save as] in the Job sub-menu to save a new job and insert a new name.

The new job will be based on the last job loaded.

Deleting a Job

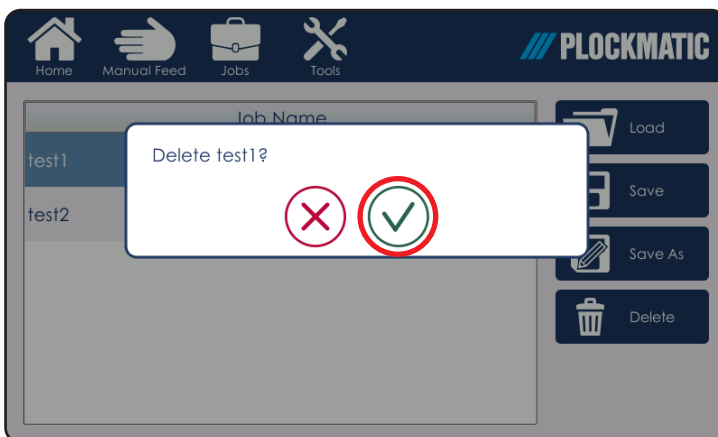

Select a Job from the saved Jobs list and delete it by pressing [Delete].

Confirm you want to delete the job by pressing on the green check mark.

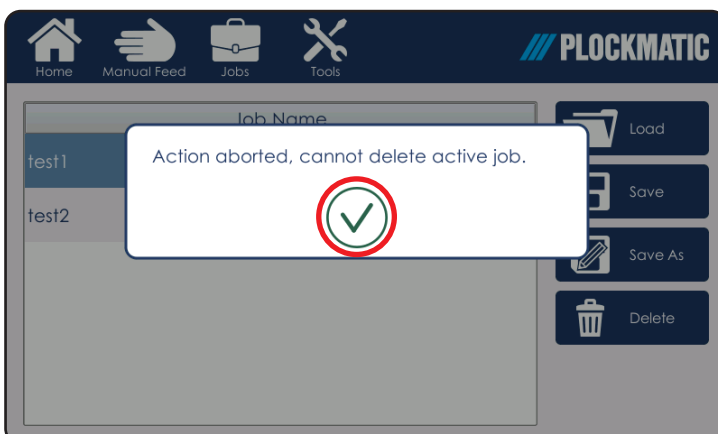

NOTE: deleting an active job is not possible.

CIP Training Plockmatic SquareBack Trimmer

Tools

The Tools Menu

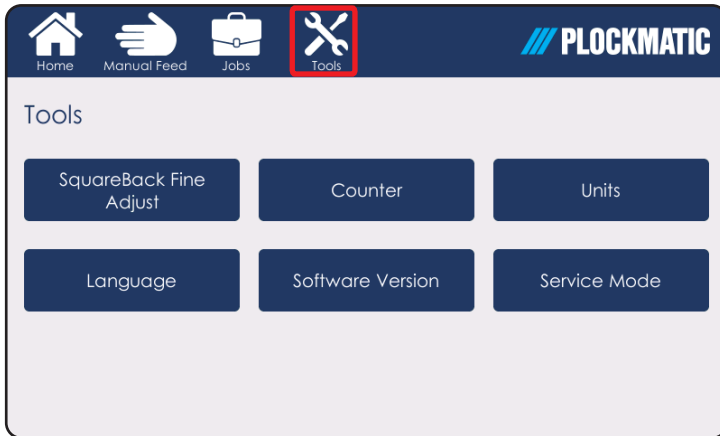

Tools

The Tools sub-menu contains a number of options that will allow the user to:

- *Fine adjust settings for the Square Back option,*
- *View and reset the counter,*
- *Choose the Units,*
- *Select the language,*
- *View the Software Version installed on the machine.*

The Service Mode is to be used only by authorized technicians.

Square Back Fine Adjustment

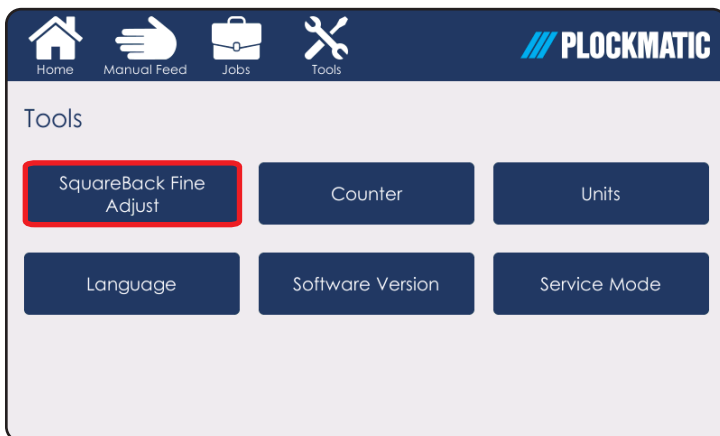

Square Back Fine Adjustment

Press [Square Back Fine Adjust] to get to the Fine Adjustment sub-menu. This function works as a pre-adjustment for the Square Back function and should be used **only** if the regular adjustment of the Square Back of the booklet does not give the expected results (see sections 2 and 3 of this manual).

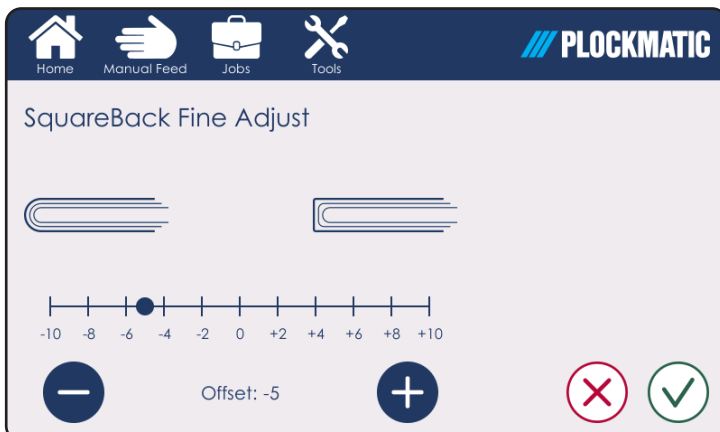

If the machine produces a too sharp or too soft fold on the booklets, the user can lower or increase its Square Back preset by pressing [+] for sharper edges and [-] for softer edges.

Press the Green Check mark to confirm the changes and return to the previous menu. Otherwise, press the red cross to discard changes and return to the previous menu.

CIP Training Plockmatic SquareBack Trimmer

Tools

Counter

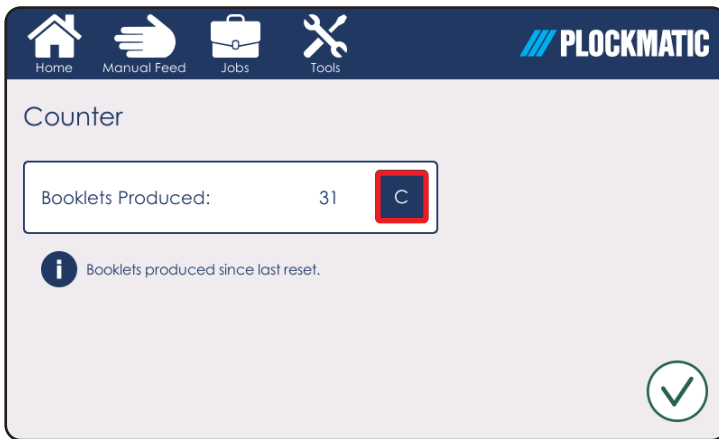

Counter

The Counter shows the number of booklet produced since its last reset.

Press [C] to reset it.

Press the Green Check mark to return to the tools menu.

Units

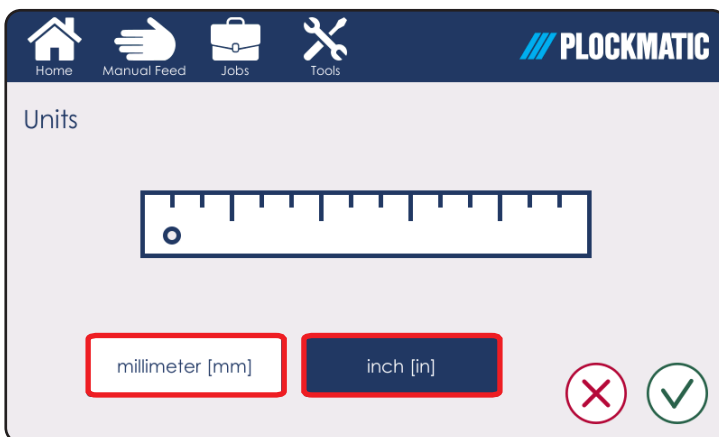

Units

This sub-menu allows the user to toggle between inches and millimetres.

NOTE: changing this setting will affect every menu in the machine.

Press the Green Check mark to confirm the changes and return to the previous menu. Otherwise, press the red cross to discard changes and return to the previous menu.

Language



Language

Select desired operating language for the machine by tapping on it.

Press the Green Check mark to confirm the changes and return to the previous menu. Otherwise, press the red cross to discard changes and return to the previous menu.

CIP Training Plockmatic SquareBack Trimmer

Tools

Software Version

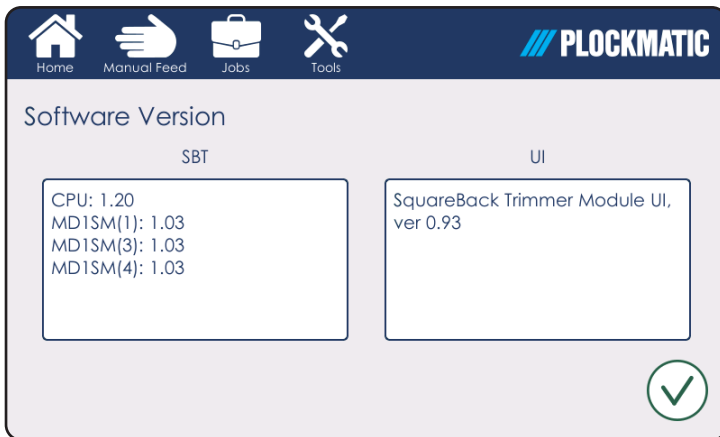

Software Version

Press [Software Version] to get to the Software Version sub-menu.

This sub-menu allows the user to check the installed software version on both the Graphical User Interface and on the Main Module.

Press the Green Check mark to return to the previous menu.

Service Mode

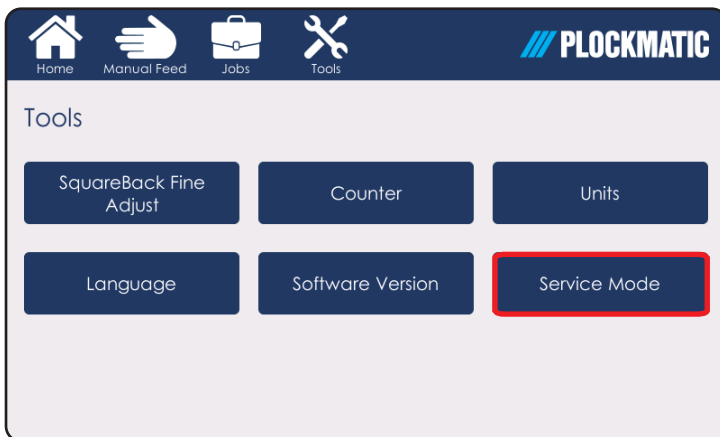

Service Mode

This function is for authorized service personnel only and is password protected.

Troubleshooting

Jams

When there is either a missfeed or a fault condition in the machine, a message and a code will be displayed on the GUI. Some codes, mainly the ones regarding jams, may be rectified by the operator but fault codes may only be rectified by a certified service technician.

If a job is cancelled or if there is a jam, there might be an incomplete set inside the SquareBack Trimmer. This set has to be manually removed from the system by opening and closing the Top Cover: this will purge the set. If the set is not purged, it has to be removed by hand.

⚠ WARNING:

The trim unit has two sharp knives for trimming booklets: do not touch them for any reason and at any time. If service is needed, call a technician.

To address codes other than those specified below, remove any paper in the paper path and power off and on the system.

If the fault code persists, contact a certified service technician.

Jam codes list

Code #	Area	Cause
400	Transport Module	Booklet gets stuck between Q32 and Q34.
401	Transport Module	Q32 (paper path sensor) not reached in time.
402	Transport Module	Q32 (paper path sensor) covered too long.
403	Transport Module	Q32 (paper path sensor) covered after purge.
404	Transport Module	Q34 (paper path sensor) covered too long.
405	Transport Module	Q34 (paper path sensor) activated when printer is active.
406	Transport Module	Q33 (paper path sensor) not reached in time.
407	Transport Module	Q33 (paper path sensor) covered too long.
408	Transport Module	Q33 (paper path sensor) covered after purge.
409	Transport Module	Q33 and Q13 (paper path sensors) covered too long.
410	Transport Module	Q33 and Q13 (paper path sensors) covered after purge.
411	Transport Module	Q33 and Q34 (paper path sensors) covered too long.
412	Transport Module	Q33 and Q34 (paper path sensors) covered after purge.
413	Transport Module	Paper size wrong (adjust paper size in printer and/or SBT Module).
500	Infeed	Booklet has triggered Q26 while purging.
501	Infeed	Q13 (paper path sensor) not reached in time.
502	Infeed	Q13 (paper path sensor) covered too long.
503	Infeed	Q13 (paper path sensor) covered after purge.
504	Infeed	Q14 (paper path sensor) not reached in time.
505	Infeed	Q14 (paper path sensor) covered too long.
506	Infeed	Q14 (paper path sensor) covered after purge.

Troubleshooting

Jam codes list

Code #	Area	Cause
507	Infeed	Q13 and Q14 (paper path sensors) covered too long.
508	Infeed	Q13 and Q14 (paper path sensors) covered after purge.
509	Infeed	Q13, Q14 and Q15 (paper path sensors) covered too long.
510	Infeed	Q13, Q14 and Q15 (paper path sensors) covered after purge.
511	Infeed	Q14 and Q15 (paper path sensors) covered too long.
512	Infeed	Q14 and Q15 (paper path sensors) covered after purge.
600	Trimmer	Booklet has missed Q15 or did not go past Q15, Q16 or Q17.
601	Align	Q15 (paper path sensor) not reached in time.
602	Align	Q15 (paper path sensor) covered too long.
603	Align	Q15 (paper path sensor) covered after purge.
604	Clamper	Q16 (paper path sensor) not reached in time.
605	Clamper	Q16 (paper path sensor) covered too long.
606	Align	Q16 (paper path sensor) covered after purge.
607	Exit	Q17 (paper path sensor) not reached in time.
608	Exit	Q17 (paper path sensor) covered too long.
609	Exit	Q17 (paper path sensor) covered after purge.
610	Align / Clamper	Q15 and Q16 (paper path sensors) covered too long.
611	Align / Clamper	Q15 and Q16 (paper path sensors) covered after purge.
612	Align / Clamper	Q15, Q16 and Q17 (paper path sensors) covered too long.
613	Align / Clamper	Q15, Q16 and Q17 (paper path sensors) covered after purge.
614	Align / Clamper	Q16 and Q17 (paper path sensors) covered too long.
615	Align / Clamper	Q16 and Q17 (paper path sensors) covered after purge.
616	Stacker	Stacker is full.
701	Waste bin	Waste bin is full.

Clearing a jam condition

⚠ WARNING:

The trim unit has two sharp knives for trimming booklets: do not touch them for any reason and at any time. If service is needed, call a technician.

If any of the jams listed in the table above is triggered, please follow these guidelines:

- Open the top covers and remove any booklet stuck in the paper path;
- Check for misfed sheets and remove them;
- Check for debris on the paper path and remove them;
- Check that booklets on the stacker do not block path of exiting booklets;
- Ensure there are no obstructions in the paper path;
- Wipe all sensors (do not use any fluid to clean them);
- Make sure the paper size is set correctly;
- Power off and power on the machine.

CIP Training Plockmatic SquareBack Trimmer

Other Messages

Cover Open Messages

Cover Open

Please close the indicated cover.

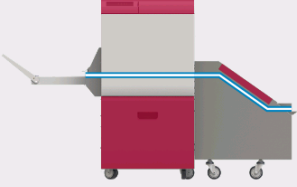

The Cover Open Messages warn the user that one / several cover(s) is/are open. Close the indicated cover(s) to clear the message.

Empty Waste Bin

Empty Waste Bin

Please empty the waste bin.



Empty Waste Bin

Empty the Waste Bin to clear this message. See procedure for how to empty the Waste Bin under the "Basics" section of this manual.

Stacker Full

Stacker Full

Please empty the stacker.

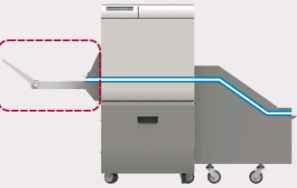

Stacker Full

This message is shown when the Stacker is full.

Remove the booklets from the stacker to clear this message.

Other Messages

Power Save Mode

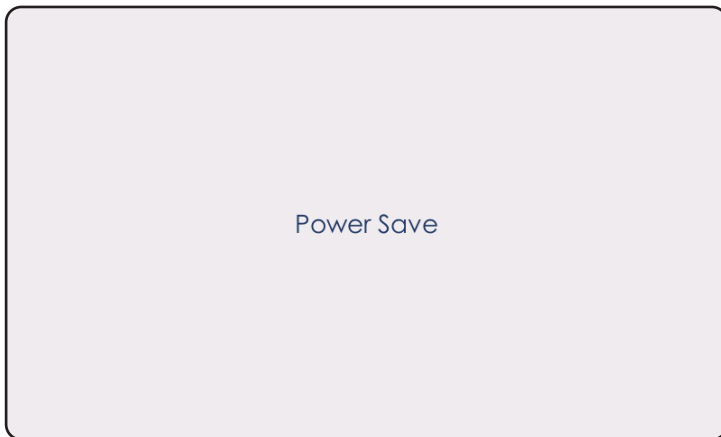

Power Save Mode

This screen is shown when the machine has not been in use for 20 minutes.

Tap on the GUI to exit the Power Save Mode.

Please Wait Screen



The "Please Wait" screen is shown under normal operation when the machine is calibrating or initializing.

Wait until a new screen is shown.

CIP Training Plockmatic SquareBack Trimmer

Do's And Don'ts

- Always follow all warnings marked on, or supplied with, the equipment.
- Always exercise care in moving or relocating the equipment.
- ⚠ **CAUTION:**
Unplug the power cord from the wall outlet and machine before you move or relocate the equipment.
- Do not remove the covers or guards that are fastened with screws.
- Do not override or bypass electrical or mechanical interlock devices.
- Do not operate the equipment if you notice unusual noises or odors. Disconnect the power cord from the power source and call your authorized technician to correct the problem.
- ⚠ **WARNING:**
Do not put fingers or other parts between moving parts.
- Do not switch off the main power switch while machine is running.

⚠ WARNING:

The trim unit (in red) has two sharp knives for trimming booklets: do not touch them for any reason and at any time. If service is needed, call a technician.

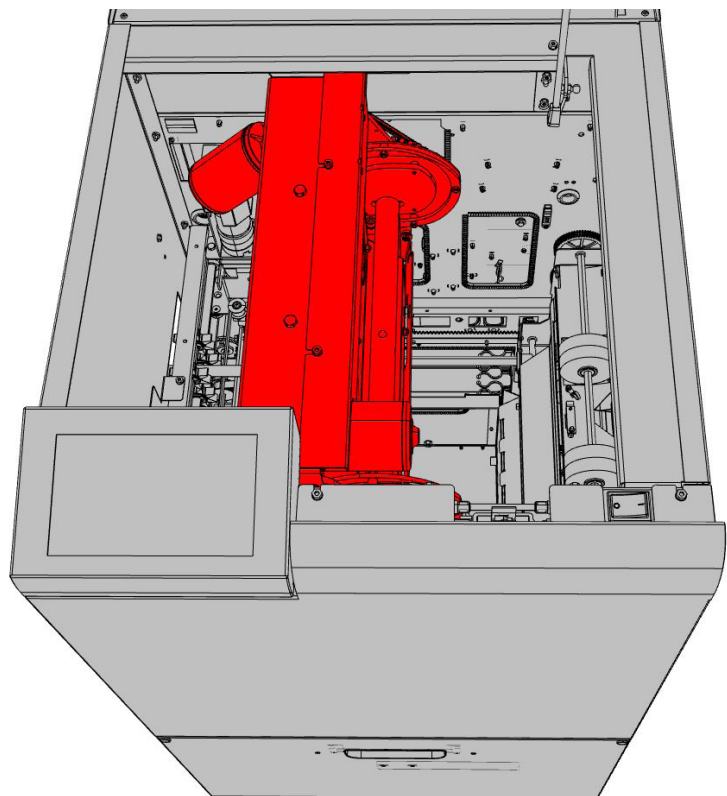

Where to put Your Machine

Machine environment

- **Always** locate the equipment on a solid support surface with adequate strength for the weight of the machine.
- Always keep magnets and all devices with strong magnetic fields away from the machine.

If the place of installation is air-conditioned or heated, do not place the machine where it will be:

- Subjected to sudden temperature changes.
- Directly exposed to cool air from air-conditioner.
- Directly exposed to heat from heater.
- Directly exposed to sunlight.

Power connection

- **Always** connect the equipment to a properly grounded power source. If in doubt, have the power source checked by a qualified electrician.
-  **WARNING:**
Improper grounding of the equipment can result in electrical shock.
- **Never** connect the machine to a power source that lacks a ground connection terminal.

Maintaining Your Machine

Never attempt any maintenance function that is not specifically described in this documentation.

Cleaning the sensors

The sensors need to be cleaned regularly when in use and if the unit has not been used for a period of time.

Sensors must be wiped clean with a lint free cloth.

⚠ CAUTION:
Never use cleaning fluids on sensors.

- ⚠ WARNING:**
- Turn the machine off before cleaning the sensors;
 - The trim unit has two sharp knives for trimming booklets: make sure not to touch them when cleaning the sensors.

Sensors' location



CIP Training Plockmatic SquareBack Trimmer

Maintaining Your Machine

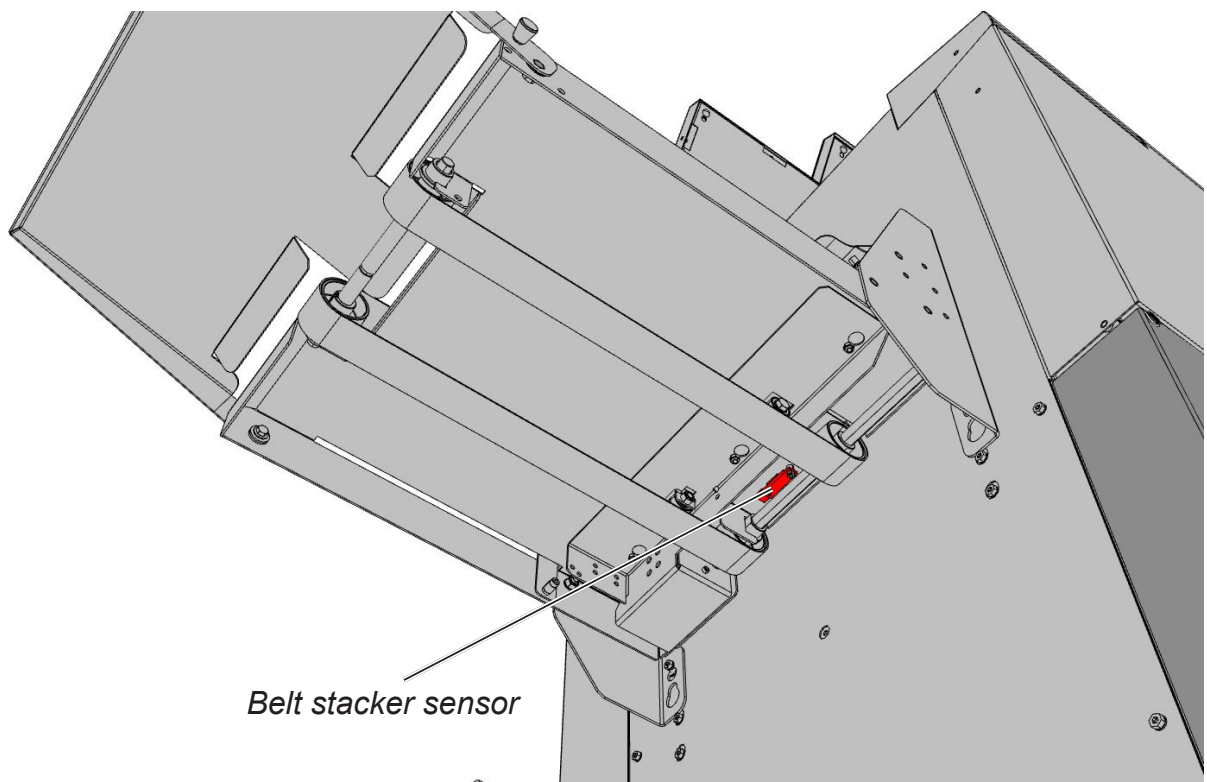
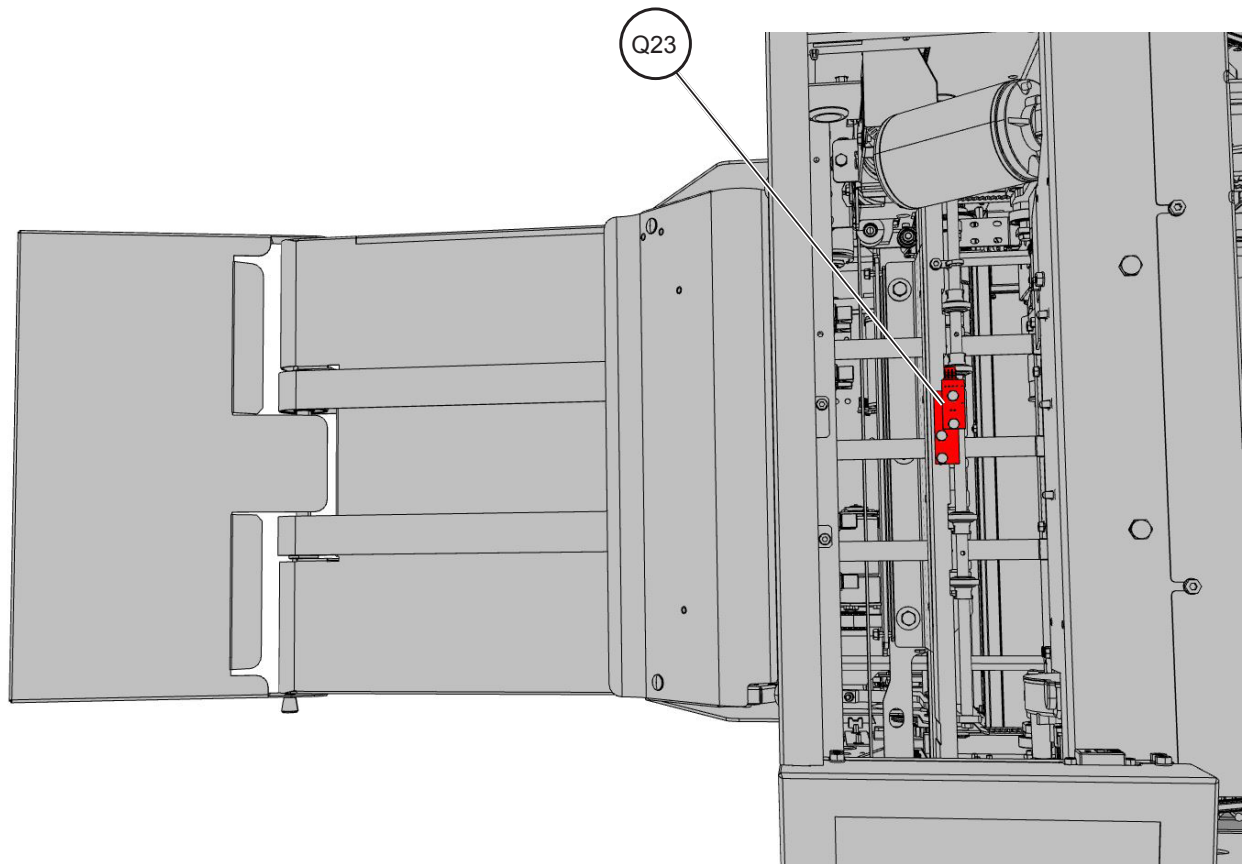

CIP Training Plockmatic SquareBack Trimmer

Maintaining Your Machine

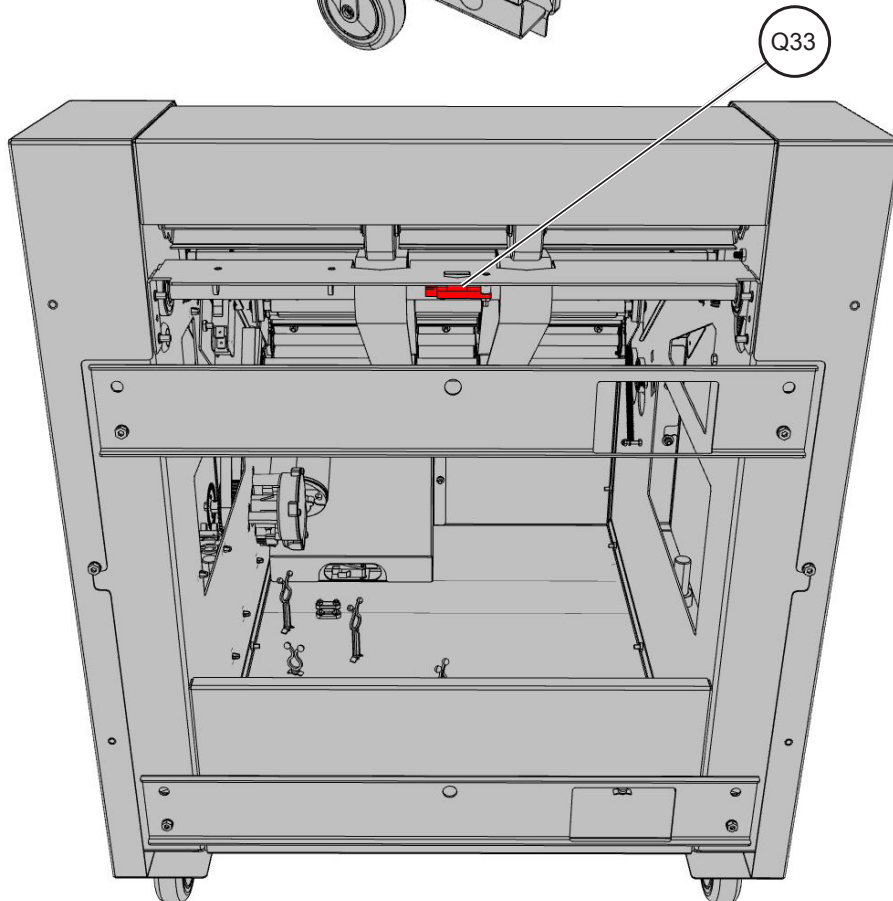
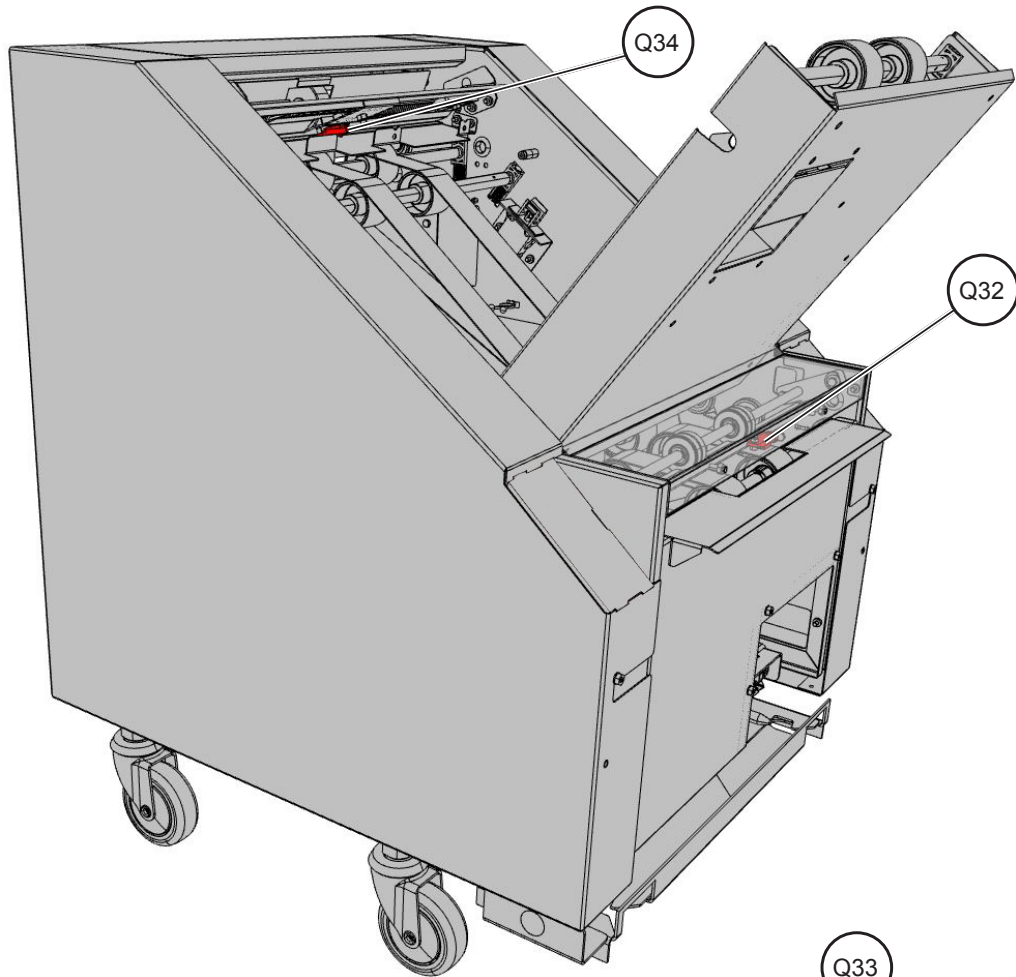

CIP Training Plockmatic SquareBack Trimmer

Operational Best Practices

- Make sure to have the correct settings for thin or thick booklet: thin booklet is thinner than 1.3 mm (0.051") and equals approximately to 6 sheets 80 g/m (see section 3 of this manual: "Booklet size" for more information about this);
- Recommended book fold interval, minimum number of sheets:
 - 64 GSMM = 9 heets,
 - 80 GSMM = 6 heets,
 - 90 GSM = 5 sheets,
 - 120-140 GSM = 4 sheets,
 - 200-220 GSM = 3 sheets,
 - 280-350 GSM = 2 sheets.
- If average book fold result is not satisfying, please see section 5 of this manual: "Square Back Fine Adjustment";
- Minimum trim for each cut is 1 mm, but to avoid trim waste on the stacked booklets recommended minimum trim would be 2 mm;
- Be cautious when using side trim. Please notice the position of the staples and set head and foot trims so that the staples are not cut;
- When using lower GSM <80 GSM use a thicker cover to get an improved fold result.

Operational Best Practices

Limitations

- The Square Back Trimmer is suited for customers whose booklet making needs will not exceed a yearly average of 15,000 booklets per month;
- If booklets entering the Square Back Trimmer are not uniform or if they are skewed, the booklet quality will vary accordingly;
- The maximum recommended number of sheets that can be bypassed without stapling is 6 sheets of 80 gsm. If there is very low friction between the sheets, running non-stapled sets may be difficult;
- Non-stapled books should not be trimmed or square folded;
- If booklets are made of paper lighter than 80GSM, the cover paper should be 80GSM or more to get an acceptable output results when square folding;
- Covers may show marking along the spine of the booklet from the clamps. The more pages in the booklet, the more evident the marking;
- Small booklets A5/ 5,5 x 8,5" or smaller may stack poorly on the conveyor;
- Booklets will not be stacked on top of each other, therefore it is recommended that the operator places a box underneath the stacker to collect the finished booklets;
- Exiting booklets might be a bit skewed;
- The booklet spine can, depending on paper quality and thickness, have different sizes of tuft at its top and at its bottom;
- If corners/edges of sheets by any reason are folded before trimming, result may look as illustrated when corners/edges are unfolded.



CIP Training Plockmatic SquareBack Trimmer

Specification

Machine Specifications

	Specifications	Remarks
Speed	4 seconds	---
Number of sheets (Maximum)	50 (80 gsm)	Also includes hand feeding. Recommended sheet and gsm interval are the same as recommended for the booklet maker.
Non-Stapled sets	6 non-stapled sheets can be bypassed through the unit.	Non-stapled sets with more than one sheet should not be trimmed or squarefolded.
Book made from minimum incoming sheet size WxL	148.5 x 210mm (5.85" x 8.27")	---
Book made from maximum incoming sheet size WxL	320 x 620mm (12.6" x 24.41")	---
Book Size Minimum WxL (in)	148.5 x 105mm (A6 book) (5.85" x 4.13")	---
Book Size Maximum WxL (in)	320 x 310mm (12.6" x 12.20")	---
Book Size Minimum WxL (out)	148.5 x 100mm (5.85" x 4.13")	---
Paper Weight (Minimum)	63 gsm	---
Paper Weight (Maximum)	350 gsm	---
Media Support	Plain paper / Recycled paper / Printed paper / Coated paper / Glossy coated paper / Matte coated paper / Textured paper / Synthetic paper	---
Maximum trimming (one cut)	210 mm (8.27")	---
Minimum trimming (one cut)	1 mm (0.04")	---
Modify Trim setting when processing	±3 mm (0.12")	---
3 Side Trim specifications	Number of sheets: 1-8; Minimum GSM for cover: 120 gsm; Minimum book length / width (in): 148.5 mm / 5.85"	
SBT Main module WxD: SBT Max Wheel Height: SBT Min Wheel Height: Transport module WxD: Stacker Max Length WxD:	~525 x 700 mm (20.67" x 27.56") ~1065 mm (41.93") ~1000 mm (39.37") ~605 x 513 mm (23.82" x 20.20") ~691 x 384 mm (27.20" x 15.12")	
Weight: Main module + stacker Transport module	~140 kg ~30 kg	
Electrical Requirements	Universal power supply 100-240 V + 6%/-10%, 50-60 Hz	

CIP Training Plockmatic SquareBack Trimmer

Specification

Machine Specifications

Environmental requirements		
Temp Range	15-30°C	
Humidity	30-80% RH	

Plockmatic uses open source code in parts of this product.
Plockmatic uses QT open source license (LGPL) to develop the software used in this machine (<https://www.qt.io/qt-licensing-terms>).

CIP Training Plockmatic SquareBack Trimmer

Specification



EU DECLARATION OF CONFORMITY [1]

No. [2] **N0007280 (A.2)**

Manufacturer [3] Plockmatic International AB, Telefonvägen 30, S-126 26 Hägersten, Sweden

This Declaration of Conformity is issued under the sole responsibility of the manufacturer [4]

Object of the Declaration [5]		
Model/Type [6]	F133-001	F133-002
Name [7]	SFT, SquareFold Trim Module	SBT, SquareBack Trim Module
Description [8]	Off line square-forming and trimming unit	In-line square-forming and trimming unit

The object of the declaration is in conformity with the relevant Union harmonization legislation: [9]	
Directive [10]	Standard [11]
2014/30/EU (EMC)	EN 55032:2015, EN 55035:2017, IEC 61000-3-2:2014, IEC 61000-3-3:2013, IEC 61000-6-2:2005, EN 61000-6-4:2007+A1:2011
2015/863/EU (RoHS)	EN 50581:2012, EN 62321:2009
2014/35/EU (LVD)	EN 62368-1:2014
Additional information [12] International certification: UL 62368-1, 2nd Edition, CSA C22.2 No. 62368-1:2014, IEC 62368-1:2014, FCC Part 15 (2015) Subpart B Section 15, Class A.	
Signed for and on behalf of [13] Hägersten, 2019-08-12 15:21	
 Bengt Olenfalk Group Quality Manager	

БЪЛГАРСКИ; 1) ЕС Декларация за съответствие; 2) Номер; 3) Производител; 4) Настоящата декларация за съответствие е издадена на отговорността на производителя; 5) Предмет на декларацията; 6) Модел/Тип; 7) Назначение; 8) Описание; 9) Предметът на декларацията, описан по-горе, отговаря на съответното законодателство на Съюза за хармонизация; 10) Директива; 11) Стандарт; 12) Допълнителна информация; 13) Подписано за и от името на

ČESKY; 1) EU Prohlášení o shodě; 2) Číslo; 3) Výrobce; 4) Toto prohlášení o shodě se vydává na výhradní odpovědnost výrobce; 5) Předmět prohlášení; 6) Model/Typ; 7) Označení; 8) Popis; 9) Výše popsany předmět prohlášení je ve shodě s příslušnými harmonizačními právními předpisy Unie; 10) Směrnice; 11) Norma; 12) Dodatečné informace; 13) Podepsáno za a jménem na

DANSK; 1) EU-Overensstemmelseserklæring; 2) Nummer; 3) Producent; 4) Denne overensstemmelseserklæring udstedes på fabrikantens ansvar; 5) Erklæringens genstand; 6) Model/Type; 7) Betegnelse; 8) Beskrivelse; 9) Genstanden for erklæringen, som beskrevet ovenfor, er i overensstemmelse med den relevante EU-harmoniseringslovgivning; 10) Direktiv; 11) Standard; 12) Yderligere information; 13) Underskrevet for og vegne

DEUTSCH; 1) EU-Konformitätserklärung; 2) Nummer; 3) Hersteller; 4) Die alleinige Verantwortung für die Ausstellung dieser Konformitätserklärung trägt der Hersteller; 5) Gegenstand der Erklärung; 6) Modell/Typ; 7) Bezeichnung; 8) Beschreibung; 9) Der oben beschriebene Gegenstand der Erklärung erfüllt die einschlägigen Harmonisierungsrechtsvorschriften der Union; 10) Direktive; 11) Standard; 12) Weitere Informationen; 13) Zur Unterzeichnung und Namen EESTI; 1) EU Vastavusdeklaratsioon; 2) Number; 3) Valmistaja; 4) Käesolev vastavusdeklaratsioon on välja antud tootja ainuvastutusel; 5) Deklareeritav; 6) Model/Type; 7) Nimetus; 8) Kirjeldus; 9) Eelkirjelatud deklareeritav toode on kooskõlas asjaomaste liidu ühtlustamisaktidega; 10) Direktiiv; 11) Standard; 12) Lisainfo; 13) Alkirkjastatud ja nimel

SUOMI; 1) EU-Vaatumustenmukaisuusvakuutus; 2) Määrä; 3) Valmistaja; 4) Tämä vaatustenmukaisuusvakuutus on annettu valmistajan yksinomaista vastuulla; 5) Vakuutuksen kohde; 6) Malli/tyyppi; 7) Nimitys; 8) Kuvaus; 9) Edellä kuvattu vakuutuksen kohde on asiaa koskevan unionin yhdenmukaistamislaainsäädännön vaatimusten mukainen; 10) Direktiivi; 11) Standardi; 12) Lisäinformaatio; 13) Allekirjoitettu ja puolesta

FRANÇAIS; 1) Déclaration UE de conformité; 2) Nombre; 3) Fabricant; 4) La présente déclaration de conformité est établie sous la seule responsabilité du fabricant; 5) Objet de la déclaration; 6) Modèle/type; 7) Désignation; 8) Description; 9) L'objet de la déclaration décrit ci-dessus est conforme à la législation d'harmonisation de l'Union applicable; 10) Directif; 11) Standard; 12) Information Supplémentaire; 13) Signé pour et au nom de

GAEILGE; 1) Dearbhú comhréireachta AE; 2) Uimhir; 3) Manufacturer; 4) Tá an dearbhú comhréireachta arna eisiúint faoi threagracht an mhonaróra; 5) Cuspóir an dearbhairthe; 6) Cineál; 7) Ainmní; 8) Tuairisc; 9) Is é cuspóir an dearbhairthe a thugtar i gcomhréir leis an reachtaíocht chomhchuibhithe ábhartha an Aontais; 10) Treoir; 11) Caighdeánach; 12) Eolas breise; 13) Arna shíniú le haghaidh agus thar ceann an

ΕΛΛΗΝΙΚΗ; 1) Δήλωση συμμόρφωσης ΕΕ; 2) αριθμός; 3) Κατασκευαστής; 4) Η παρούσα δήλωση συμμόρφωσης εκδίδεται με αποκλειστική ευθύνη του κατασκευαστή; 5) Αντικείμενο της δήλωσης; 6) Μοντέλο/Τύπος; 7) Ονομασία; 8) Περιγραφή; 9) Ο στόχος της δήλωσης που περιγράφεται παραπάνω είναι σύμφωνος με τη σχετική ενωσιακή νομοθεσία εναρμόνισης; 10) διευθυντικός; 11) Πρότυπο; 12) Επιπλέον πληροφορίες; 13) Υπογραφή για λογαριασμό και εξ ονόματος του

HRVATSKI; 1) EU Izjava o sukladnosti; 2) Broj; 3) Proizvođač; 4) Za izdavanje EU izjave o sukladnosti odgovoran je isključivo proizvođač; 5) Predmet deklaracije; 6) Model/Tip; 7) Oznaka; 8) Deskripcija; 9) Predmet navedene izjave u skladu je s mjerodavnim zakonodavstvom Unije o uskladjivanju; 10) Direktiva; 11) Standard; 12) Dodatne informacije; 13) Potpisao za iu ime

MAGYAR; 1) EU-Megfelelőségi nyilatkozat; 2) Szám; 3) Gyártó; 4) Ezt a megfeleléségi nyilatkozatot a gyártó kizárólagos felelőssége mellett adja ki; 5) A nyilatkozat tárgya; 6) Modell/Típus; 7) Kijelölés; 8) Leírás; 9) A fent ismertetett nyilatkozat tárgya megfelel a vonatkozó uniós harmonizációs jogszabályoknak; 10) Irányelv; 11) Standard; 12) További információ; 13) Aláírva nevében

ISLENSKA; 1) ESB Leyfisýrfrýsing; 2) Fjöldi; 3) Framleiðandi; 4) Þessi samræmisýrfrýsing er sett afháði á ábyrgð framleiðanda; 5) Markmið ýrfrýsingarinnar; 6) Gerð; 7) Tilnefning; 8) Lýsing; 9) Markmið ýrfrýsingarinnar lýst er hér að ofan er í samræmi við viðeigandi Union samhæfingu löggjafar; 10) Tilskipun; 11) Standard; 12) Viðbótarupplýsingar; 13) Undirritað fyrir og fyrir hönd

ITALIANO; 1) Dichiarazione di conformità UE; 2) Numero; 3) Produttore; 4) La presente dichiarazione di conformità è rilasciata sotto la responsabilità esclusiva del fabbricante; 5) Oggetto della dichiarazione; 6) Modello/Tip; 7) Designazione; 8) Descrizione; 9) L'oggetto della dichiarazione di cui sopra è conforme alla pertinente normativa di armonizzazione dell'Unione; 10) Direttiva; 11) Standard; 12) Informazioni aggiuntive; 13) Firmato e per conto di

LATVIEŠU; 1) ES Atbilstības deklarācija; 2) Numurs; 3) Ražotājs; 4) Št atbilstības deklarācija ir izdota vienīgi uz ražotāja atbildību; 5) Deklarācijas priekšmets; 6) Modelis/tips; 7) Apzīmējums; 8) Apraksts; 9) Iepriekš aprakstītais deklarācijas priekšmets atbilst attiecīgajam Savienības saskaņošanas tiesību aktam; 10) Direktīva; 11) Standarts; 12) Papildus informācija; 13) Parakstīts vārdā

LĪETUVIŪ; 1) ES Atitikties deklaracija; 2) Skaičius; 3) Gamintojas; 4) Ši atitikties deklaracija išduota tik gamintojo atsakomybe; 5) Deklaracijos objektas; 6) Modelis/tipas; 7) Pavadinimas; 8) Aprašymas; 9) Pirmiau aprašytas deklaracijos objektas atitinka susijusių derinamųjų Sąjungos teisės aktus; 10) Direktyva; 11) Standartinė; 12) Papildoma informacija; 13) Pasirašyta ir vardu

MALTESE; 1) Dikjarazzjoni ta' konformità ta' UE; 2) Numru; 3) Manifattur; 4) Din id-dikjarazzjoni ta' konformità tinhareg taht ir-responsabbiltà unika ta'-manifattur; 5) Għan tad-dikjarazzjoni; 6) Mudell/Tip; 7) Deżinjazzjoni; 8) Deskrizzjoni; 9) L-għan tad-dikjarazzjoni deskritt hawn fuq huwa konformi mal-leġislazzjoni ta' armonizzazzjoni rilevanti ta'Unjoni; 10) Direttiva; 11) Standard; 12) Informazzjoni addizzjonali; 13) Iffirmat għal u f'isem il

NETERLANDS; 1) EU-Conformiteitsverklaring; 2) Nummer; 3) Fabrikant; 4) Deze conformiteitsverklaring wordt verstrekt onder volledige verantwoordelijkheid van de fabrikant; 5) Voorwerp van de verklaring; 6) Model/Type; 7) Benaming; 8) Beschrijving; 9) Het hierboven beschreven voorwerp is in overeenstemming met de desbetreffende harmonisatiewetgeving van de Unie; 10) Richtlijn; 11) Standaard; 12) Aanvullende informatie; 13) Ondertekend voor een namens

NORSK; 1) EU-Erklæring; 2) Nummer; 3) Producent; 4) Denne samsvarserklæringen er utstedt under ansvar av produsenten; 5) Formålet med erklæringen; 6) Type; 7) Betegnelse; 8) Beskrivelse; 9) Formålet med erklæringen som er beskrevet ovenfor er i samsvar med relevante Union harmoniseringslovgivning; 10) Direktiv; 11) Standard; 12) Ytterligere informasjon; 13) Signert for og vegne av

POLSKI; 1) Deklaracja zgodności UE; 2) Numer; 3) Producent; 4) Niniejsza deklaracja zgodności wydana zostaje na wyłączną odpowiedzialność producenta; 5) Przedmiot deklaracji; 6) Model/Typ; 7) Oznaczenie; 8) Opis; 9) Wymieniony powyżej przedmiot niniejszej deklaracji jest zgodny z odpowiednimi wymaganiami unijnego prawodawstwa harmonizacyjnego; 10) Dyrektywa; 11) Standard; 12) Dodatkowe informacje; 13) Podpisano imieniem

PORTUGUÊS; 1) Declaração UE de conformidade; 2) Número; 3) Fabricante; 4) A presente declaração de conformidade é emitida sob a exclusiva responsabilidade do fabricante; 5) Objecto da declaração; 6) Modelo/Tipo; 7) A denominação; 8) Descrição; 9) O objecto da declaração acima descrito está em conformidade com a legislação de harmonização da União aplicável; 10) Directiva; 11) Padrão; 12) Informações adicionais; 13) Assinado por e nome

ROMÂNĂ; 1) Declarația UE de conformitate; 2) Număr; 3) Producător; 4) Prezenta declarație de conformitate este emisă pe răspunderea exclusivă a producătorului; 5) Obiectul declarației; 6) Model/Tip; 7) Desemnare; 8) Descriere; 9) Obiectul declarației descris mai sus este în conformitate cu legislația relevantă de armonizare a Uniunii; 10) Directivă; 11) Standard; 12) Informații adiționale; 13) Semnat pentru și în numele

SLOVENSKY; 1) EU Vyhlášení o zhode; 2) Číslo; 3) Výrobca; 4) Toto vyhlášení o zhode sa vydáva na výhradnú zodpovednosť výrobcu; 5) Predmet vyhlásenia; 6) Model/Typ; 7) Označenie; 8) Popis; 9) Uvedený predmet vyhlásenia je v zhode s príslušnými harmonizačnými právnymi predpismi Unie; 10) Smernice; 11) Štandardné; 12) Dopĺňajúce informácie; 13) Podpísané za a mene na

SLOVENŠČINA; 1) Izjava EU o skladnosti; 2) Številko; 3) Proizvajalec; 4) Ta izjava o skladnosti je izdana na lastno odgovornost proizvajalca; 5) Predmet izjave; 6) Model/Type; 7) Oznaka; 8) Opis; 9) Predmet navedene izjave je v skladu z ustreznimi zakonodajno Unije o harmonizaciji; 10) Direktiva; 11) Standardna; 12) Dodatne informacije; 13) Podpisano za in v imenu

ESPAÑOL; 1) Declaración UE de conformidad; 2) Número; 3) Fabricante; 4) La presente declaración de conformidad se expide bajo la exclusiva responsabilidad del fabricante; 5) Objeto de la declaración; 6) Tipo de modelo; 7) Designación; 8) Descripción; 9) El objeto de la declaración descrita anteriormente es conforme con la legislación de armonización pertinente de la Unión; 10) Directiva; 11) Estándar; 12) Información Adicional; 13) Firmado por y nombre

SVENSKA; 1) EU-Försäkran om överensstämmelse; 2) Nummer; 3) Tillverkare; 4) Denna försäkran om överensstämmelse utfärdas på tillverkarens eget ansvar; 5) Föremålet för försäkran; 6) Modell/Typ; 7) Beteckning; 8) Beskrivning; 9) Föremålet för försäkran ovan överensstämmer med den relevanta harmoniserade unionslagstiftningen; 10) Direktiv; 11) Standard; 12) Extra information; 13) Undertecknat för och på uppdrag av

RICOH
imagine. change.